

In the Box:

- Tray Assembly
- Add-On Frame Assembly
- Hardware Bag
- Security bolts

Step 1:

- Pivot Base Rack into the Storage position (parallel to the rear of vehicle).
- Remove both plastic caps found in Tap Plate of Base Rack and partially thread in two supplied Security Bolts.

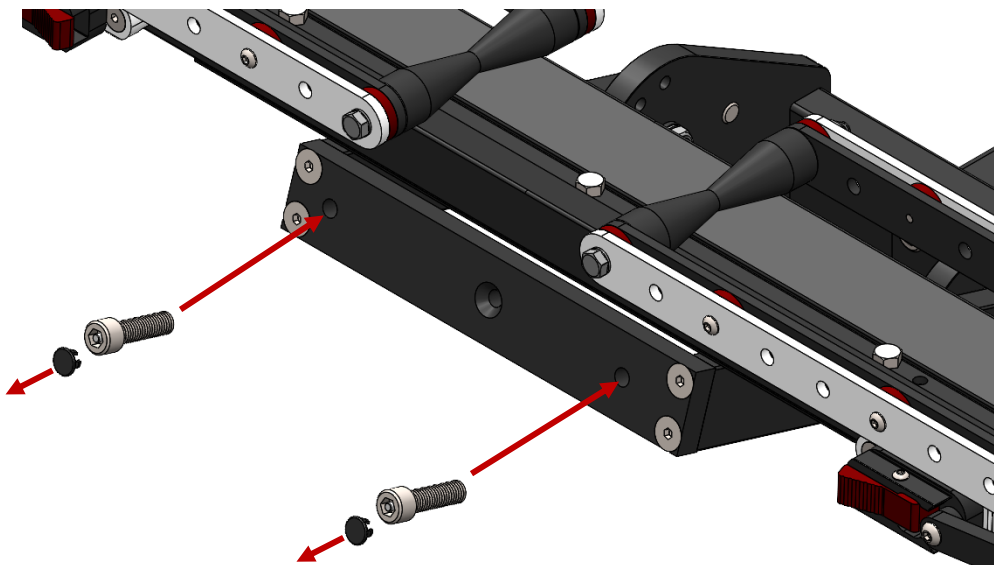

Step 2:

- Place Add-On onto base rack by aligning Key Hole Plate slots with installed Security Bolts.
- Slide Add-On to right engaging Security Bolts into narrow portion of Key Hole Plate slots.
- With Base Rack Security Wrench, tighten Security Bolts.

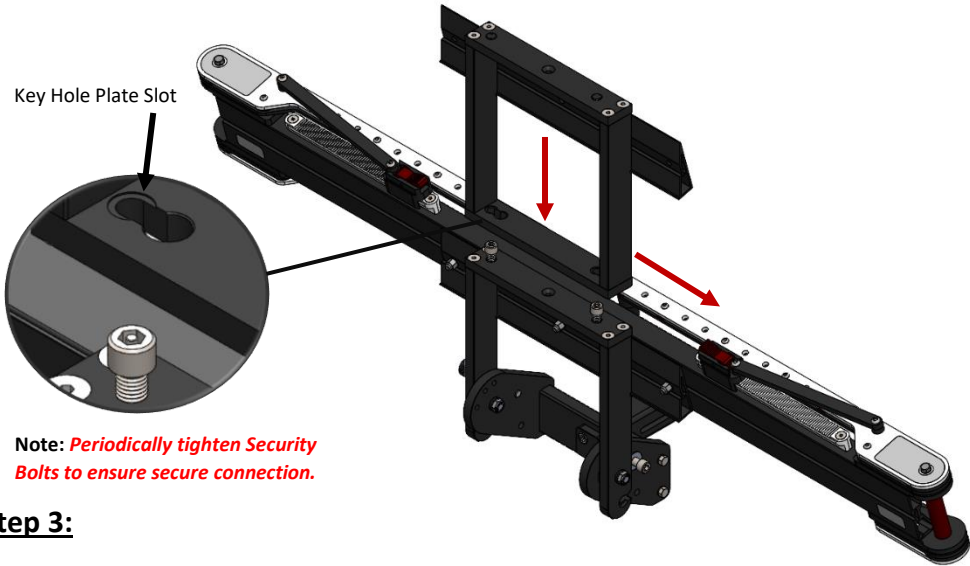

Step 3:

- Place Tray Assembly on 15 Degree Plate with Domino facing out.
- Insert 3/8-16 x 1.75" hex bolts through Tray and 15 Degree Plate.
 - Ensure middle 3 holes are used on Tray.
 - Ensure bolts are fully seated in Tray channel.
- Place 3/8" washer and nut on each bolt.
- Use 9/16" wrench to tighten.

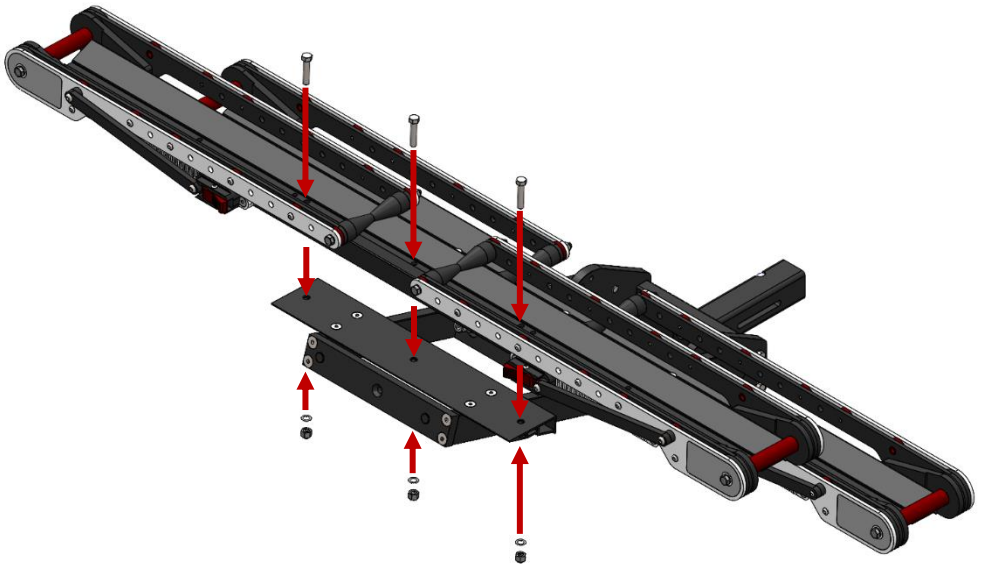

Note: *Do not overtighten. Overtightening may cause damage to rack.*

Installing Add-On Lock (if applicable)

Not included with Add-On purchase (sold separately)

- If Add-On is already installed to base rack, remove right Security Bolt. If installing a new Add-On, Add-On Lock Bolt will be applied to right threaded hole of Base Rack Tap Plate.
- Slide locking washer and flat washer over Add-On Lock Bolt and thread into Tap Plate hole.
- With Base Rack Security Wrench, tighten Add-On Lock Bolt.
- Apply Lock Head to end of Add-On Lock Bolt. Key must be inserted and turned to install Lock Head.

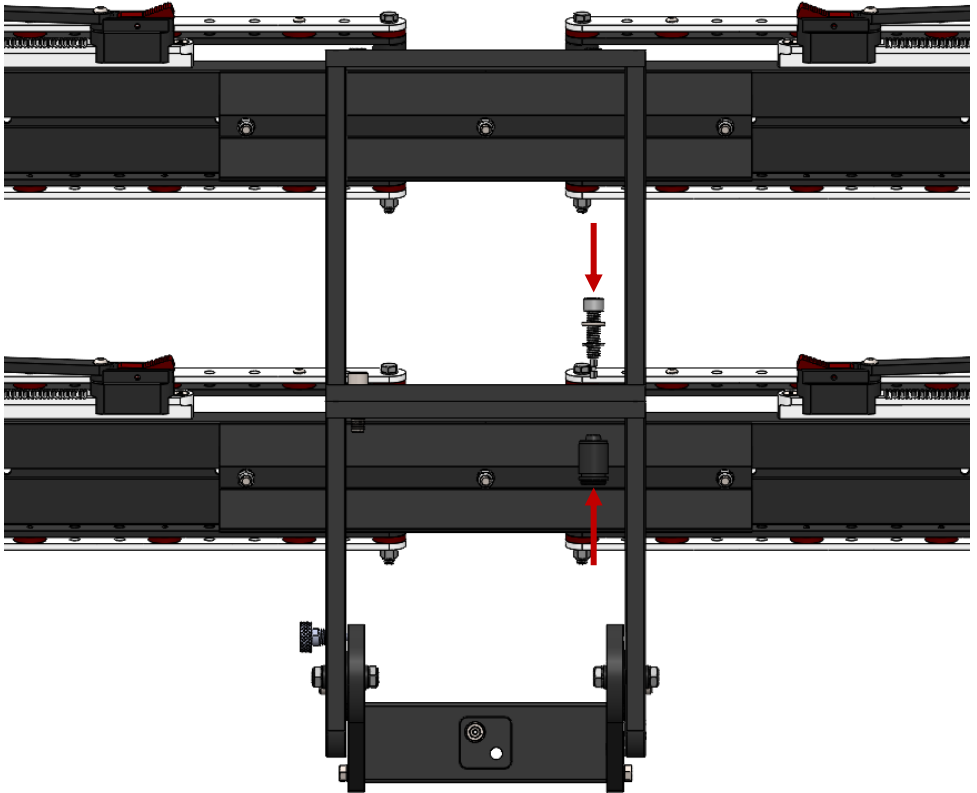

Additional Instructions

- Remove road debris off nuts and bolts to prevent corrosion.
- Inspect hardware periodically to ensure proper working conditions.
- Certain car wash chemicals may damage Accessory finish. Please use caution when cleaning vehicle and/or Accessory.

Questions or comments? Contact our support team via email at email@1up-usa.com