

Parts List:

- 1) Wheel Catch
- 2) Wheel Catch Mount
- 3) Tray Mount
- 4) Knob

Tools Required:

- 1) 7/32" Allen Wrench (included)

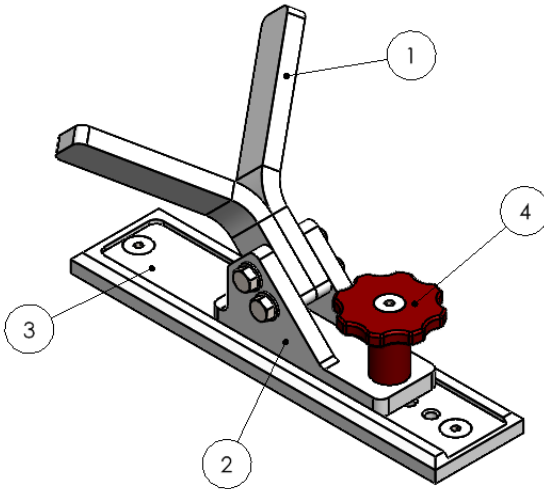

In the Box

- Wheel Chock Assembly
- Knob Assembly
- Tray Mount
- Hardware Packet

Product Notes

- Compatible with Moto Rack.
- Wheel Chock compatible with tires up to 7" wide.

Installing Wheel Chock

- Open Bent Arm Assemblies until perpendicular with Tray.
- Remove two 3/8"-16 Button Head Screws from top of Tray where front wheel of Bike will sit.
- Install Tray Mount Plate with adjustment holes towards center of Rack using 3/8"-16 Flat Head Screws.

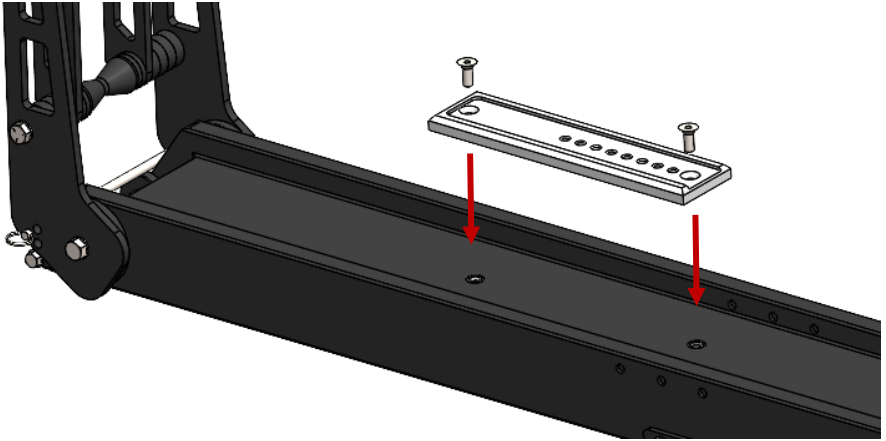

Using Wheel Chock

- With Bike loaded on Rack, slide Wheel Chock onto Tray Mount Plate until contacting front tire.
- Tighten Wheel Chock Knob through Wheel Chock and firmly into closest adjustment hole of Tray Mount to lock Wheel Chock in place.

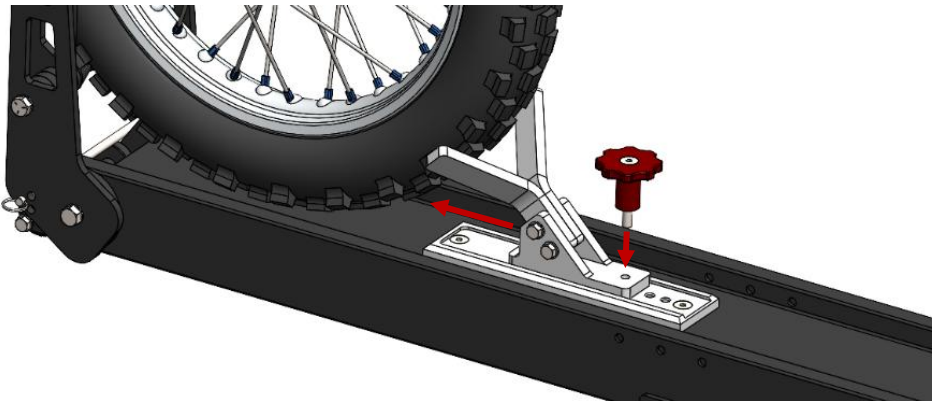

- Tension Ratchet Assembly on Wheel Chock side first to seat front tire into Wheel Catch.
- Tension other Ratchet Assembly to evenly secure Bike.

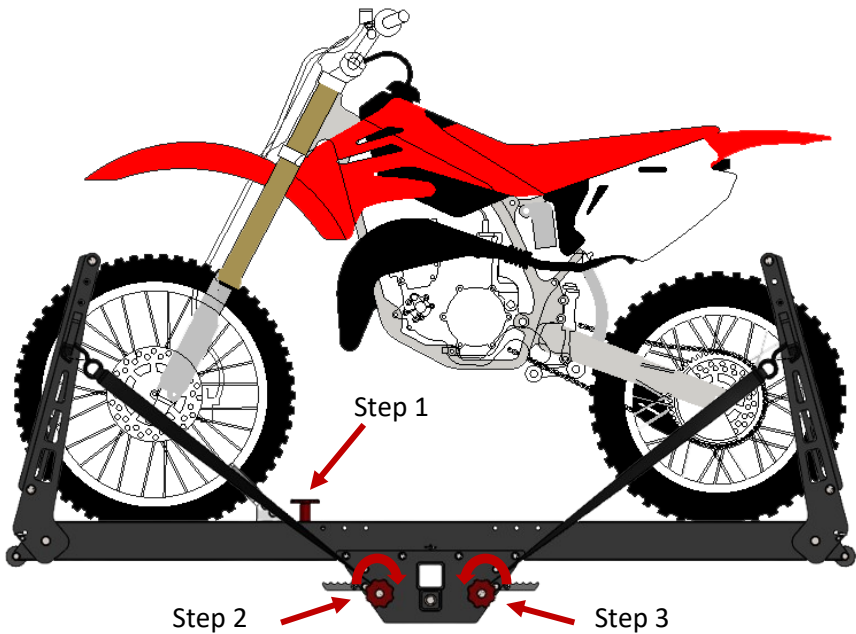

- To remove Wheel Chock, reverse steps above.

Note: *Wheel Chock must be removed prior to loading and unloading Bike. Tray Mount can stay attached to Tray.*

Additional Instructions

- Remove road debris off nuts and bolts to prevent corrosion.
- Inspect hardware on Accessory periodically to ensure proper working conditions.
- Certain car wash chemicals may damage Accessory finish. Please use caution when cleaning vehicle and/or Accessory.

Questions or comments? Contact our support team via email at email@1up-usa.com