



## V STYLE RAMP

### In the Box:

- (1) Ramp
- (2) Ramp Hooks
- (4) 5/16-18 x .625" Button Head
- (4) .562" OD x .062 Thick Metal FW
- (4) 5/16-18 Jam Nylok Nut

#### One of the following:

- QR/HD Mounting Hardware
- XD/SD Mounting Hardware

### Tools Required:

- Security Wrench
- 1/2" Wrench
- 3/16" Allen Wrench

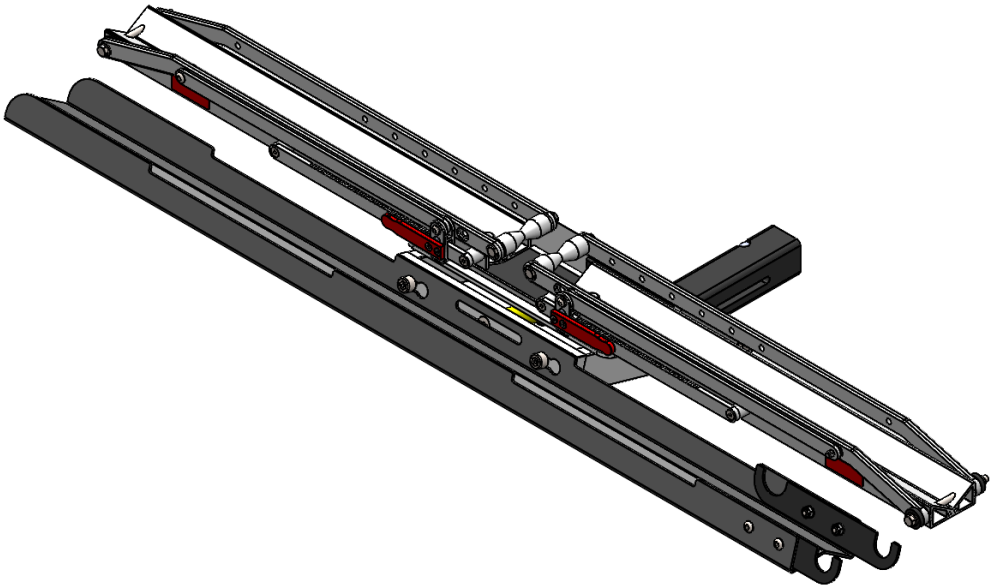

### Product Notes:

- Compatible with Quik Rack, Heavy Duty, Super Duty, and Xtreme Duty Racks.
- Unit can install on driver or passenger side tray.
- Security Wrench required for assembly.

## Assembling Ramp

1. Insert Button Head through Ramp and Ramp Hook. (Ramp Hook to be on inside of Ramp.)
2. Install Metal Washer and Jam Nyloc Nut onto Button Head. Use 3/16" Allen Wrench and 1/2" wrench to tighten.
3. Repeat steps 1-3 for remaining holes.

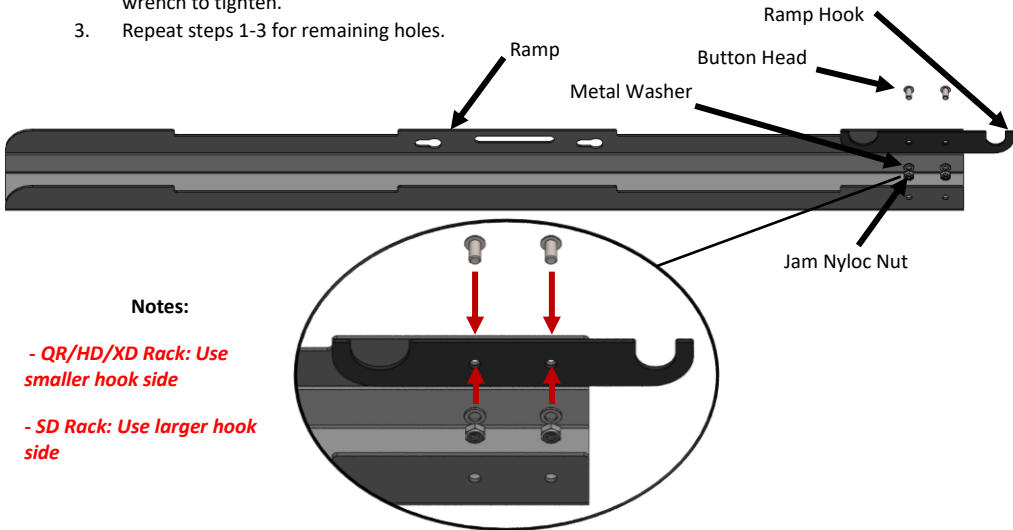

## Installation Steps

### Step 1:

- Remove Cap Plugs from Tap Plate.
- Start Bolts in Tap Plate threaded holes.

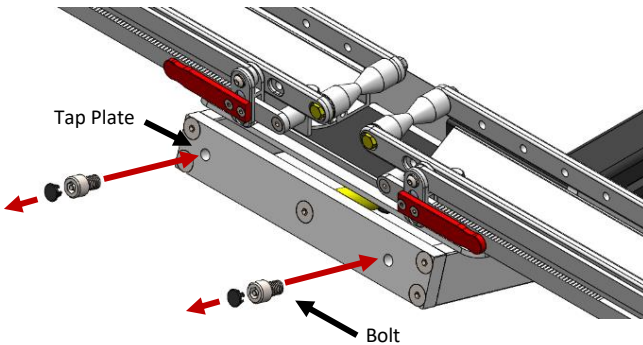

- Place V Style Ramp onto base rack by aligning keyhole slots with Bolts. Tighten Bolts.

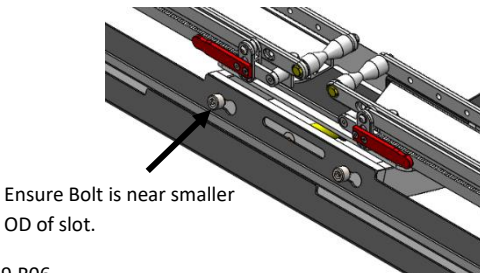

**Note: For XD/SD Rack, ramp will align between Spacer and Bolt Head.**

## Step 2:

- Use 3/16" Allen Wrench and 1/2" Wrench to remove nut and bolt holding Strap to Bent Arm.
- Install Quick Release Pin through Bent Arm, Spacer, and Strap.

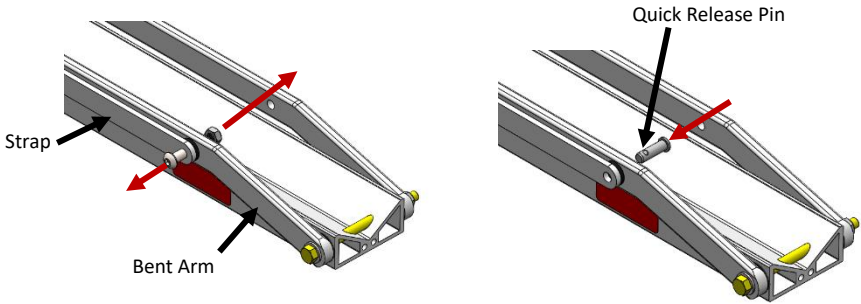

**Note:** *For XD/SD Rack, omit Step 2.*

## Step 3:

- Remove 5/16-18 x 4.5" Hex Bolt from end of Tray. Install provided hardware in sequence shown below.

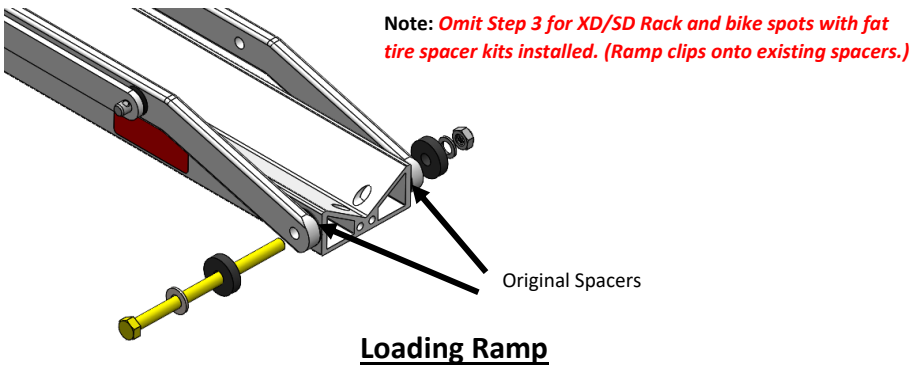

## Step 1:

- Depress spring loaded release on Quick Release Pin and remove Strap from Pin. Pin will remain in bent arm.

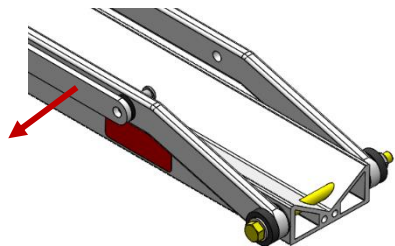
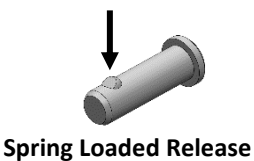

**Note:** *For, XD/SD Rack, omit Step 1*

## **Step 2:**

- Rotate Bent Arms so Spool is near ground. Ramp clips onto Plastic Spacers installed earlier (Step 3 - Installation).

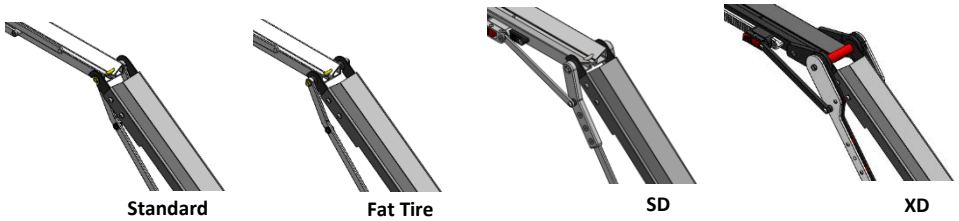

## **Step 3:**

- Roll Bike up V Style Ramp and onto Rack Trays. Use Bent Arm, opposite of ramp, to stabilize bike while loading.
- Remove Ramp and install onto Tap Plate. If applicable reinstall Strap and Quick Release Pin. Pivot bent arms into tires firmly to secure bike.

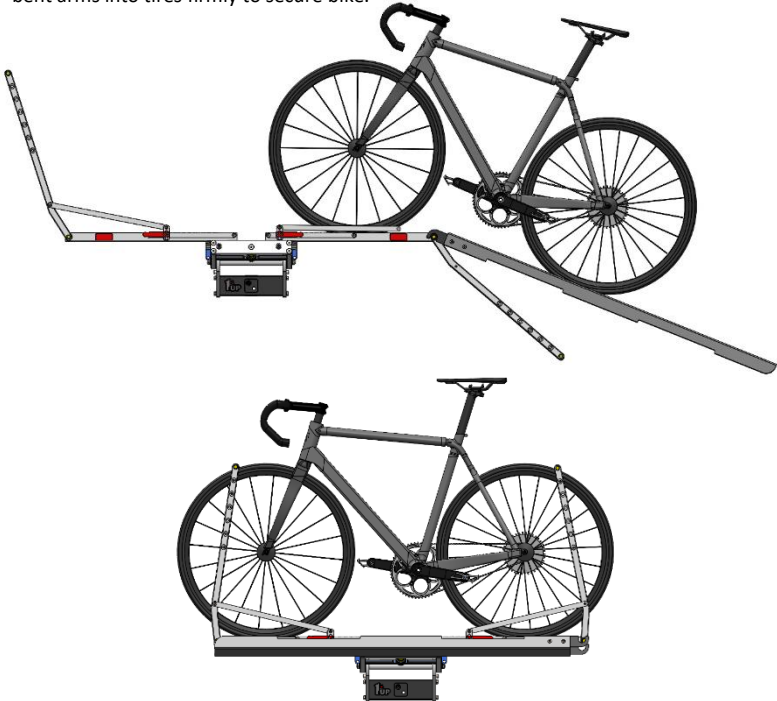

## **Additional Instructions**

- Remove road debris off nuts and bolts to prevent corrosion.
- Inspect hardware on Accessory periodically to ensure proper working conditions.
- Certain car wash chemicals may damage Accessory finish. Please use caution when cleaning vehicle and/or Accessory.

Questions or comments? Contact our support team via email at [email@1up-usa.com](mailto:email@1up-usa.com)



## V STYLE RAMP – EQUIP-D

### In the Box:

- (1) Ramp
- (2) Ramp Hooks
- (4) 5/16-18 x .625" Button Head
- (4) .562" OD x .062 Thick Metal FW
- (4) 5/16-18 Jam Nylock Nut
- (1) Quick Release Pin
- (1) Equip-D Mount
- (1) Security Wrench

### Tools Required:

- Security Wrench
- 1/2" Wrench
- 3/16" Allen Wrench
- Multitool



### Product Notes:

- Compatible with Equip-D Racks.
- Unit can install on driver or passenger side tray.
- Security Wrench required for assembly.

## Assembling Ramp

1. Insert Button Head through Ramp and Ramp Hook. (See image below for part orientation.)
2. Install Metal Washer and Jam Nylock Nut onto Button Head. Use 3/16" Allen Wrench and 1/2" wrench to tighten.
3. Repeat steps 1-3 for remaining holes.

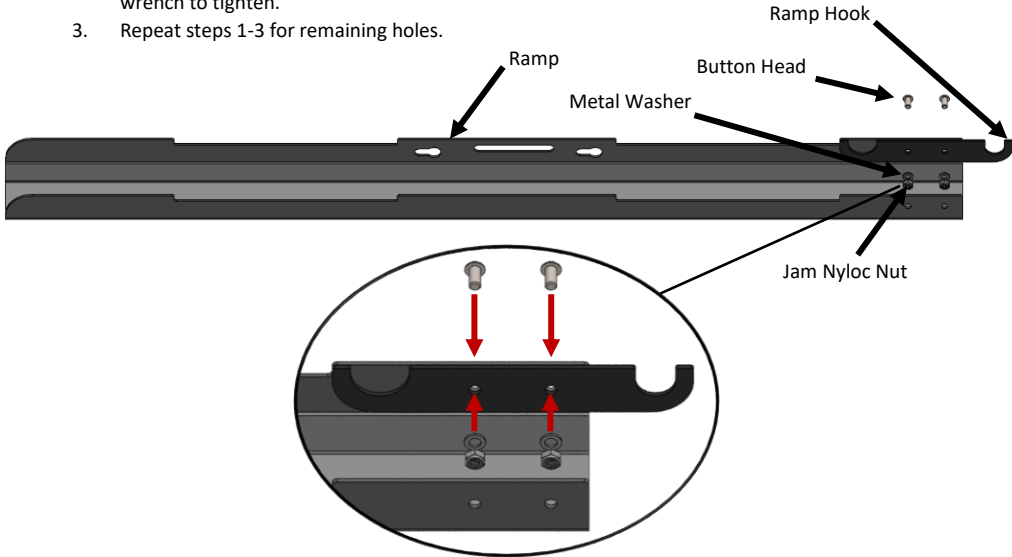

## Installation Steps

### Step 1:

- Remove Detent Pins and Handle. Use Multitool to remove all four Socket Head Screws from Endcap.

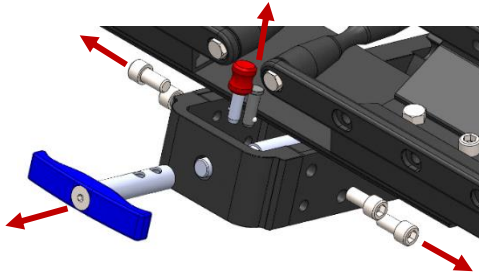

### Step 2:

- Align holes of Equip-D Mount with holes of Endcap. Reinstall Socket Head Screws to secure Equip-D Mount to rack. Tighten firmly. Reinstall Handle and Detent Pins.

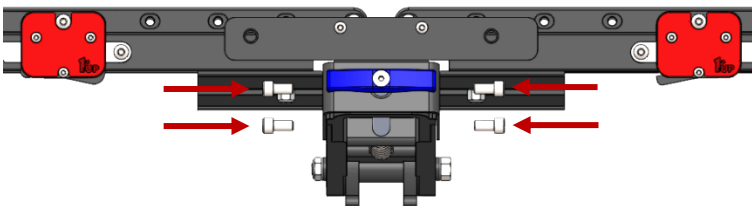

### **Step 3:**

- Place V Style Ramp onto rack by aligning keyhole slots with Security Bolts. Tighten Security Bolts.

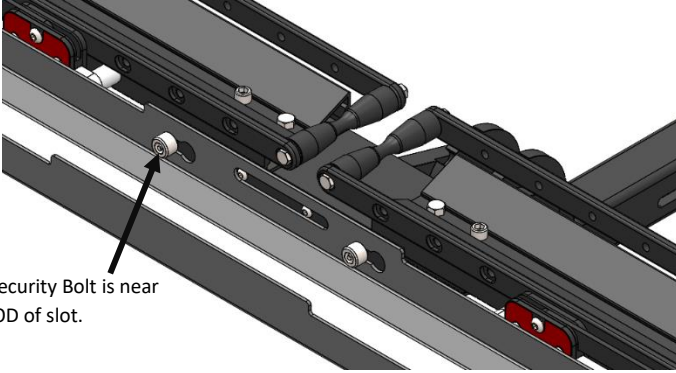

### **Step 4:**

- Use 3/16" Allen Wrench and 1/2" Wrench to remove nut and bolt holding Strap to Bent Arm.
- Install Quick Release Pin through Bent Arm, Spacer, and Strap.

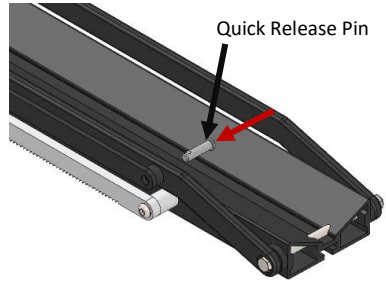
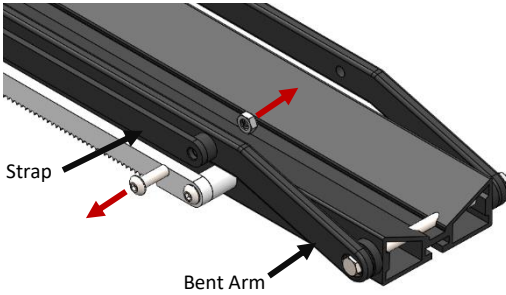

## **Loading Ramp**

### **Step 1:**

- Depress spring loaded release on Quick Release Pin and remove Strap from Pin. Pin will remain in bent arm.

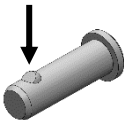

**Spring Loaded Release**

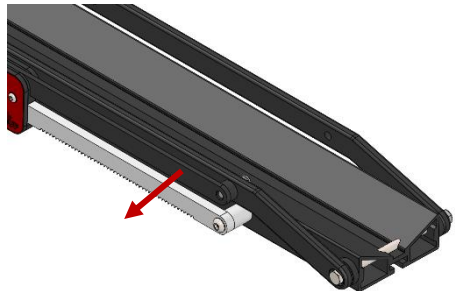

## **Step 2:**

- Rotate Bent Arms so Spool is near ground. Ramp clips onto Plastic Spacers.



## **Step 3:**

- Roll Bike up V Style Ramp and onto Rack Trays. Use Bent Arm, opposite of ramp, to stabilize bike while loading.
- Remove Ramp and install onto Equip-D Mount. Reinstall Quick Release Pin. Pivot bent arms into tires firmly to secure bike.



## **Additional Instructions**

- Remove road debris off nuts and bolts to prevent corrosion.
- Inspect hardware on Accessory periodically to ensure proper working conditions.
- Certain car wash chemicals may damage Accessory finish. Please use caution when cleaning vehicle and/or Accessory.

Questions or comments? Contact our support team via email at [email@1up-usa.com](mailto:email@1up-usa.com)





## V STYLE RAMP LONG

### In the Box:

- (1) Ramp
- (2) Ramp Hooks
- (4) 5/16-18 x .625" Button Head
- (4) .562" OD x .062 Thick Metal FW
- (2) 1/2-13 x 2.75" Socket Head
- (4) 5/16-18 Jam Nylok Nut
- (1) 3/8 x 5" Spring Pin
- (2) Ramp Spacer

#### One of the following:

- QR/HD Mounting Hardware
- XD/SD Mounting Hardware

### Tools Required:

- Security Wrench
- 1/2" Wrench
- 3/16" Allen Wrench

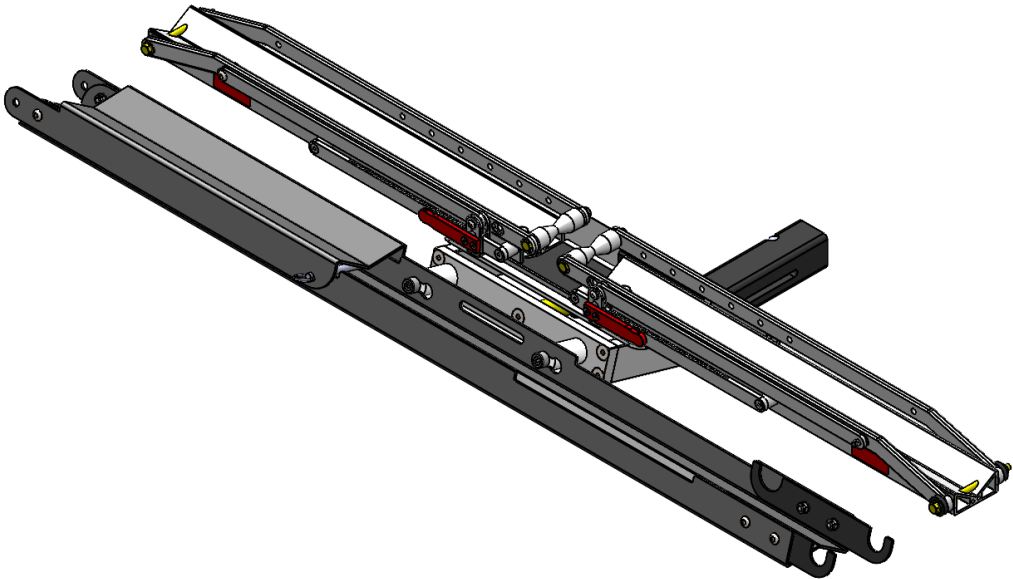

### Product Notes:

- Compatible with Quik Rack, Heavy Duty, Super Duty, and Xtreme Duty Racks.
- Unit can install on driver or passenger side tray.
- Security Wrench required for assembly.
- Unit can be used opened or closed.

## Assembling Ramp

1. Insert Button Head through Ramp and Ramp Hook. (Ramp Hook to be on inside of Ramp.)
2. Install Metal Washer and Jam Nylok Nut onto Button Head. Use 3/16" Allen Wrench and 1/2" wrench to tighten.
3. Repeat steps 1-3 for remaining holes.
4. Insert Spring Pin through Ramp holes.

### Notes:

- QR/HD/XD Rack: Use smaller hook side

- SD Rack: Use larger hook side

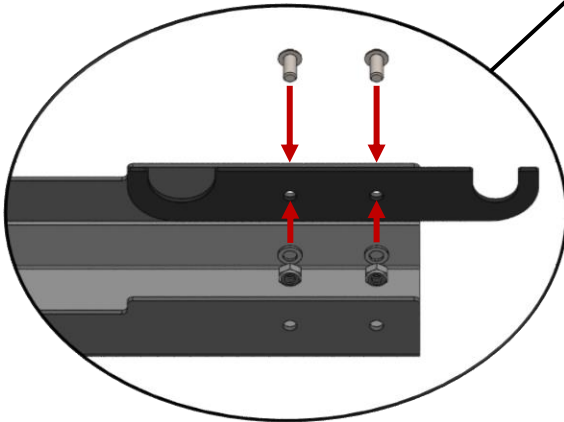
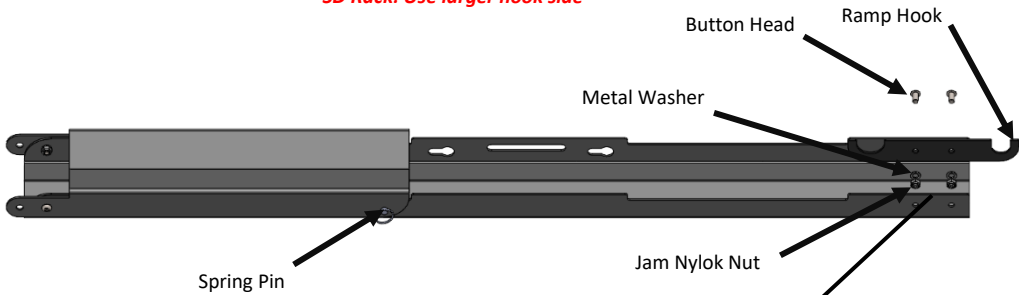

### Closed Configuration



### Open Configuration

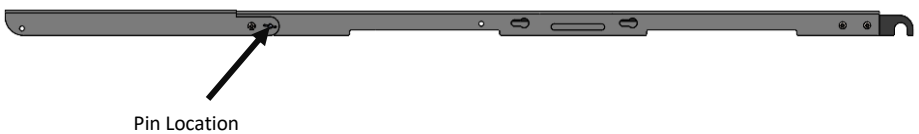

# Installation Steps

## Step 1:

- Remove Cap Plugs from Tap Plate.
- Start Socket Heads through Ramp Spacers into Tap Plate threaded holes.
- Place closed V Style Ramp Long onto base rack by aligning keyhole slots with Bolts. Tighten Bolts.

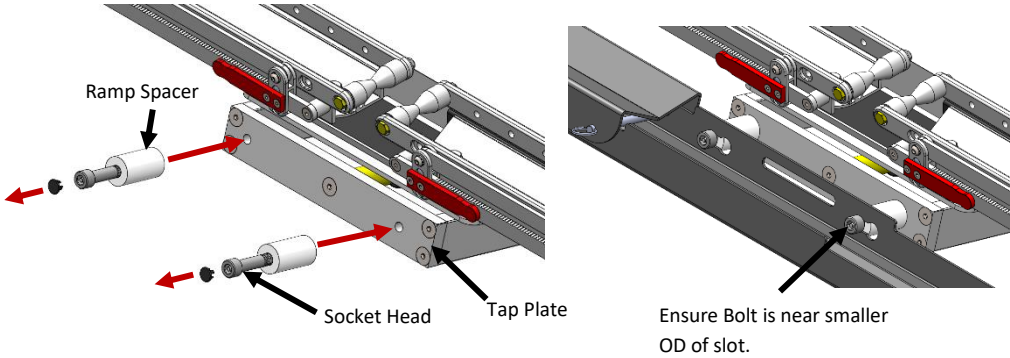

## Step 2:

- Use 3/16" Allen Wrench and 1/2" Wrench to remove nut and bolt holding Strap to Bent Arm.
- Install Quick Release Pin through Bent Arm, Spacer, and Strap.

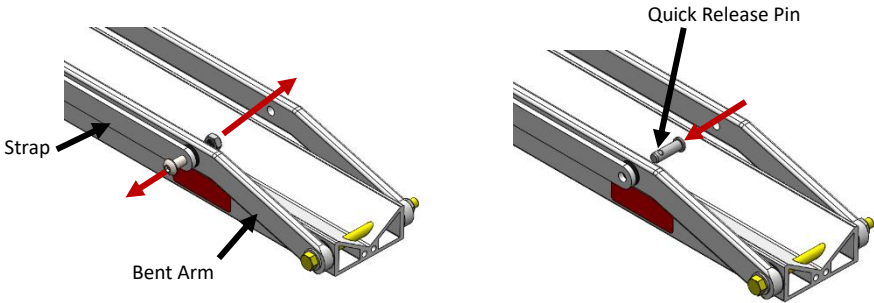

**Note: For XD/SD Rack, omit Step 2**

## Step 3:

- Remove 5/16-18 x 4.5" Hex Bolt from end of Tray and install provided hardware in sequence shown below.

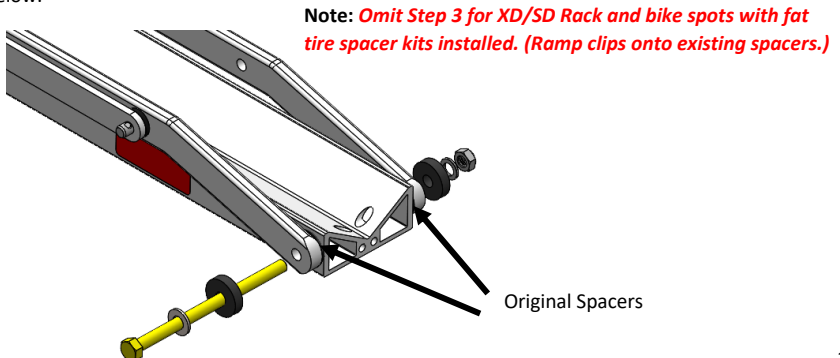

## Loading Ramp

### Step 1:

- Depress spring loaded release on Quick Release Pin and remove Strap from Pin. Pin will remain in bent arm.

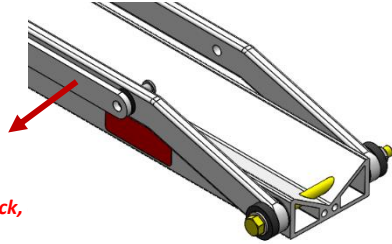
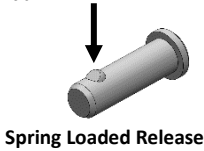

Note: *For, XD/SD Rack,*

### Step 2:

- Rotate Bent Arms so Spool is near ground. Remove Spring Pin and open Ramp. Insert Spring Pin into open position hole and clip Ramp onto Spacers (See below).

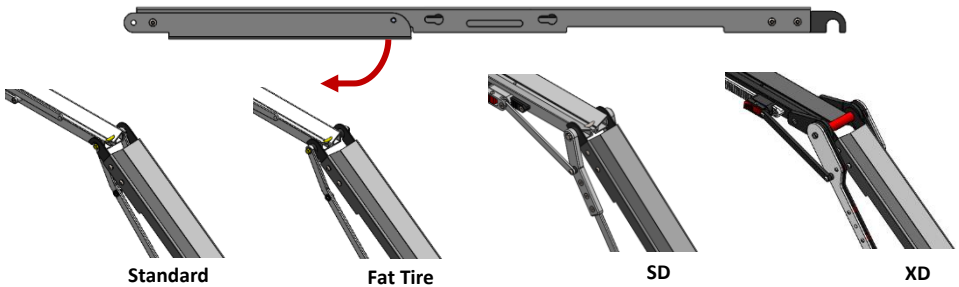

### Step 3:

- Roll Bike up V Style Ramp Long and onto Rack Trays. Use Bent Arm, opposite of ramp, to stabilize bike while loading.
- Remove Spring Pin and close Ramp. Insert Spring Pin into closed position hole and install Ramp onto Tap Plate. If applicable reinstall Strap and Quick Release Pin. Pivot bent arms into tires firmly to secure bike.

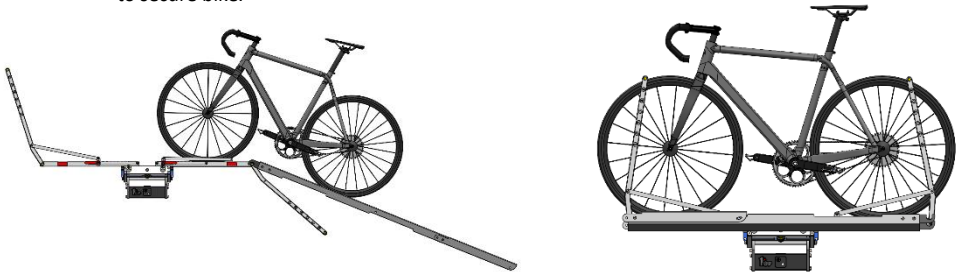

### Additional Instructions

- Remove road debris off nuts and bolts to prevent corrosion.
- Inspect hardware on Accessory periodically to ensure proper working conditions.
- Certain car wash chemicals may damage Accessory finish. Please use caution when cleaning vehicle and/or Accessory.

Questions or comments? Contact our support team via email at [email@1up-usa.com](mailto:email@1up-usa.com)



## V STYLE RAMP LONG - EQUIP-D

### In the Box:

- (1) Ramp
- (2) Ramp Hooks
- (4) 5/16-18 x .625" Button Head
- (4) .562" OD x .062 Thick Metal FW
- (4) 5/16-18 Jam Nylok Nut
- (1) Quick Release Pin
- (1) Equip-D Mount
- (1) Security Wrench
- (1) 3/8" x 5" Spring Pin
- (2) Security Bolts

### Tools Required:

- Security Wrench
- 1/2" Wrench
- 3/16" Allen Wrench
- Multitool



### Product Notes:

- Compatible with Equip-D Racks.
- Unit can install on driver or passenger side tray.
- Security Wrench required for assembly.
- Unit can be used opened or closed.

## Assembling Ramp

1. Insert Button Head through Ramp and Ramp Hook. (See image below for part orientation.)
2. Install Metal Washer and Jam Nylok Nut onto Button Head. Use 3/16" Allen Wrench and 1/2" wrench to tighten.
3. Repeat steps 1-3 for remaining holes.
4. Insert Spring Pin through Ramp holes.

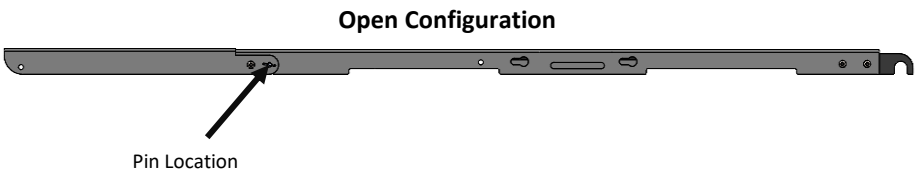
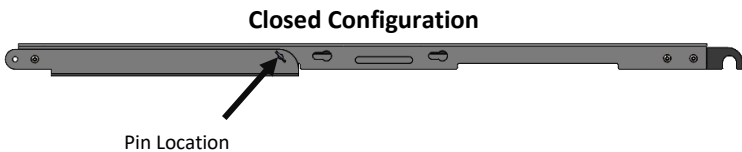
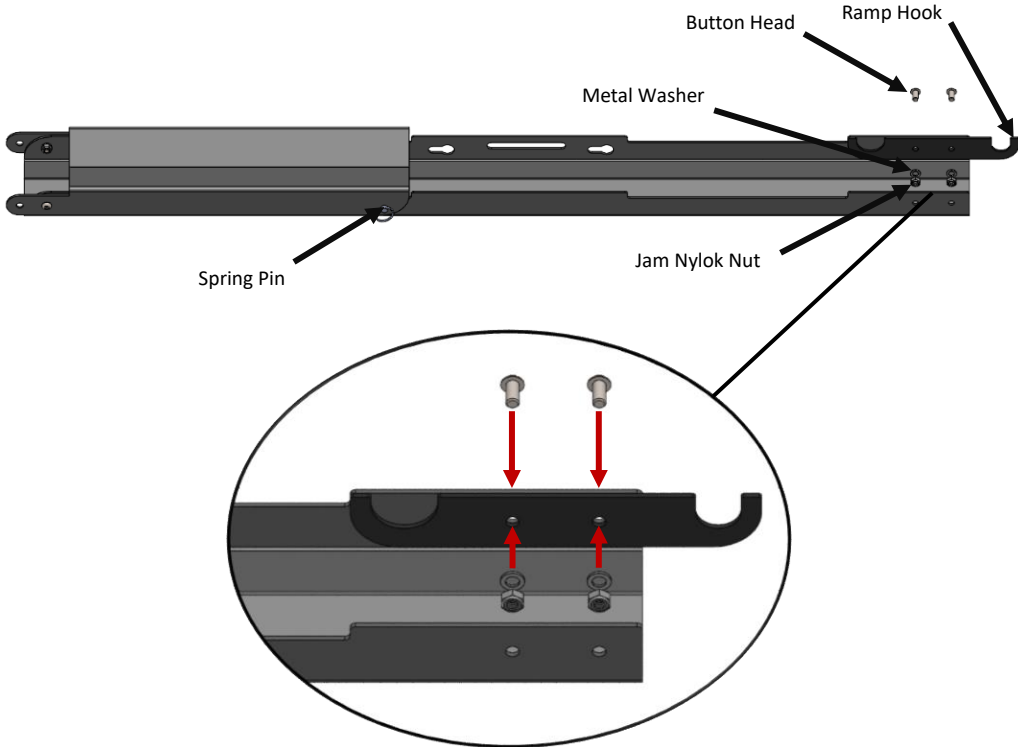

## Installation Steps

### Step 1:

- Remove Detent Pins and Handle. Use Multitool to remove all four Socket Head Screws from Endcap.

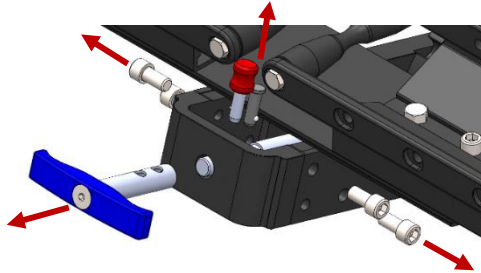

### Step 2:

- Align holes of Equip-D Mount with holes of Endcap. Reinstall Socket Head Screws to secure Equip-D Mount to rack. Tighten firmly. Reinstall Handle and Detent Pins.

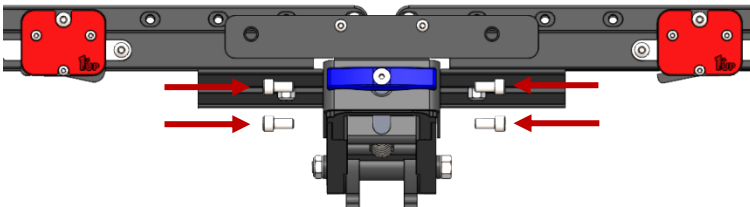

### Step 3:

- Place closed V Style Ramp Long onto rack by aligning keyhole slots with Security Bolts. Tighten Security Bolts.

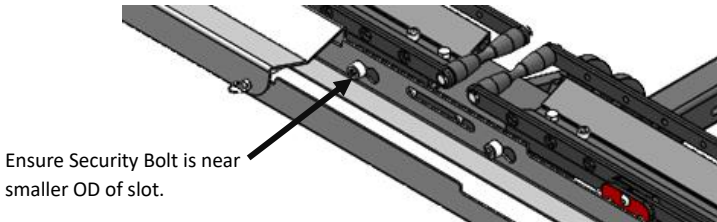

### Step 4:

- Use 3/16" Allen Wrench and 1/2" Wrench to remove nut and bolt holding Strap to Bent Arm.
- Install Quick Release Pin through Bent Arm, Spacer, and Strap.

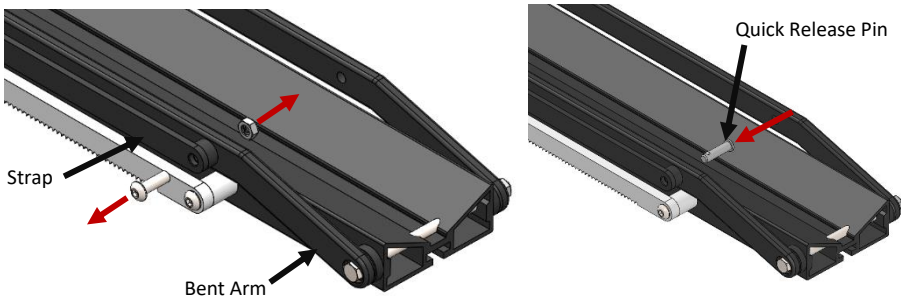

## Loading Ramp

### Step 1:

- Depress spring loaded release on Quick Release Pin and remove Strap from Pin. Pin will remain in bent arm.

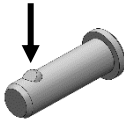

**Spring Loaded Release**

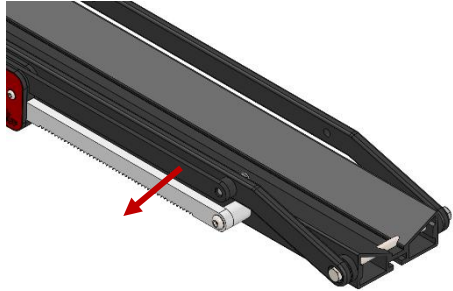

### Step 2:

- Rotate Bent Arms so Spool is near ground. Remove Spring Pin and open Ramp. Insert Spring Pin into open position hole and clip Ramp onto Plastic Spacers.



### Step 3:

- Roll Bike up V Style Ramp Long and onto Rack Trays. Use Bent Arm, opposite of ramp, to stabilize bike while loading.
- Remove Spring Pin and close Ramp. Insert Spring Pin into closed position hole and install Ramp onto Equip-D Mount. Reinstall Quick Release Pin.
- Pivot bent arms into tires firmly to secure bike.



## Additional Instructions

- Remove road debris off nuts and bolts to prevent corrosion.
- Inspect hardware on Accessory periodically to ensure proper working conditions.
- Certain car wash chemicals may damage Accessory finish. Please use caution when cleaning vehicle and/or Accessory.

Questions or comments? Contact our support team via email at [email@1up-usa.com](mailto:email@1up-usa.com)