



For additional info including video instructions, detailed weight ratings, and more, scan the code.



SUPER DUTY ROOF RACK

Parts List:

- | | |
|---------------------|--------------------|
| 1) Bent Arm Bracket | 6) Tray |
| 2) Strap | 7) Roof Rack Clamp |
| 3) Domino | 8) Carriage Bolt |
| 4) Button | 9) Barrel Nut |
| 5) Bent Arm | 10) Glide Bar |

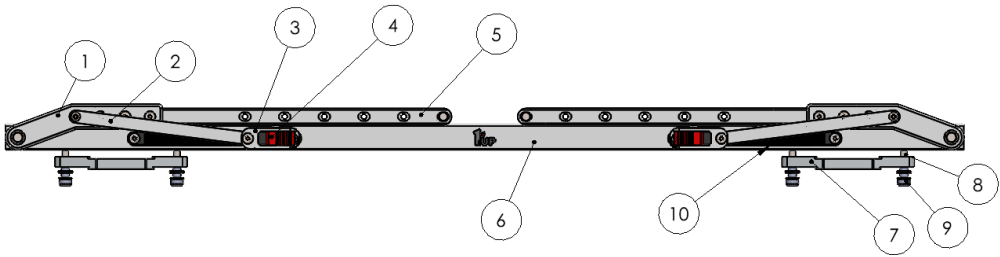

In The Box:

- 1UP USA Super Duty Roof Rack
- (2) Roof Rack Clamps
- Roof Rack Mounting Hardware

Product Notes:

- Fits 16''-29'' wheels, up to 4.9'' wide.

Mounting Rack

Step 1:

- Slide all four Carriage Bolts into bottom slot of Roof Tray.
- Position Carriage Bolts so they sit evenly spaced on vehicle's cross bars.

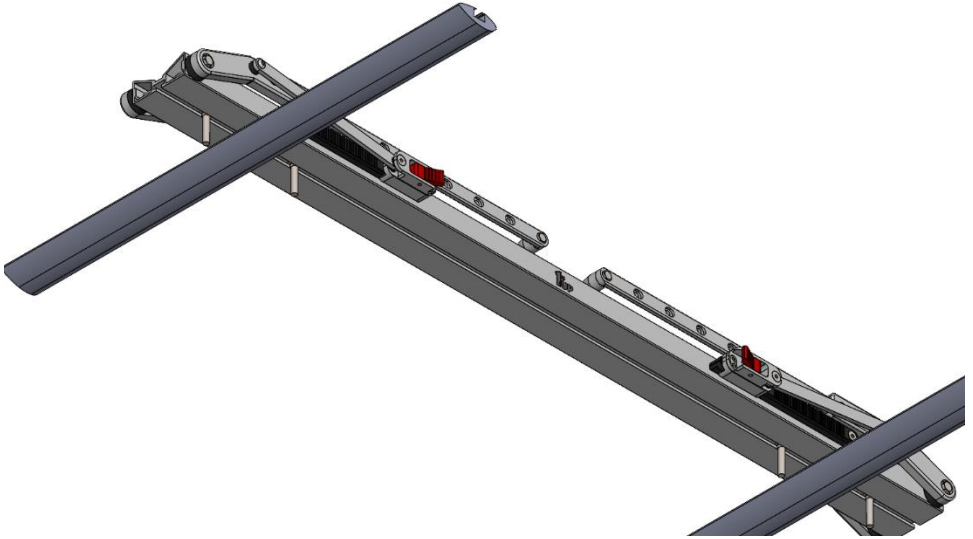

Step 2:

- Insert provided Barrel Nuts into holes of Roof Rack Clamp and position Roof Rack Clamp underneath crossbar.
- Connect Barrel Nuts and Carriage bolts, tightening by hand and then with Security Wrench.
 - Periodically check tightness of Barrel Nuts
- Repeat for second clamp.

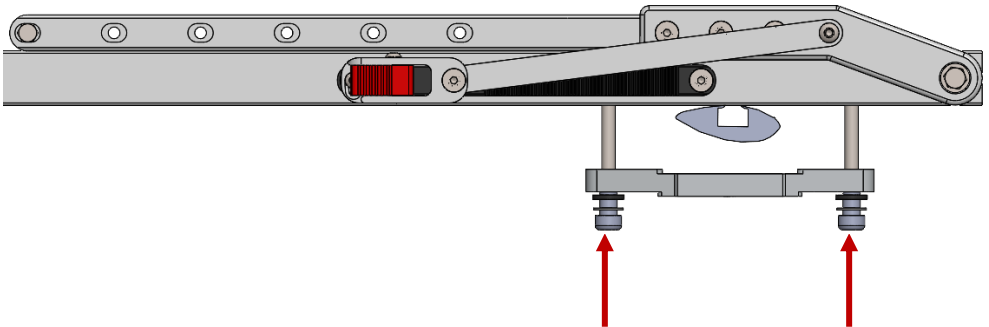

Note: *Black and Silver Washers are for adjustments in length if needed.*

Optional Flush Mount

Step 1:

- Slide two Carriage Bolts into bottom slot of Roof Tray.
- Position Roof Rack Clamp perpendicular to tray and use installed carriage bolt and jam nut to tighten clamp in place. Repeat for second clamp.

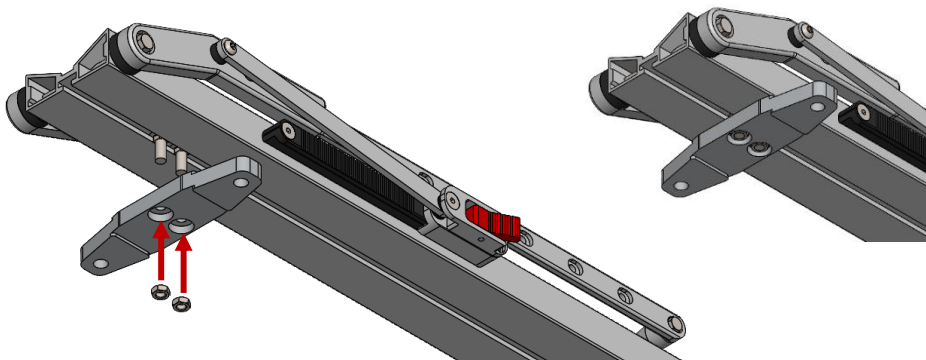

Note: *Position Roof Rack Clamps to accommodate existing crossbars.*

Step 2:

- Position two yellow Tee Nuts into crossbar allowing each hole on Roof Rack Clamp to align with its corresponding Tee Nut.
- Install Flat Head Screw through clamp and tighten into Tee Nut. Use supplied Allen Wrench to clamp firm.

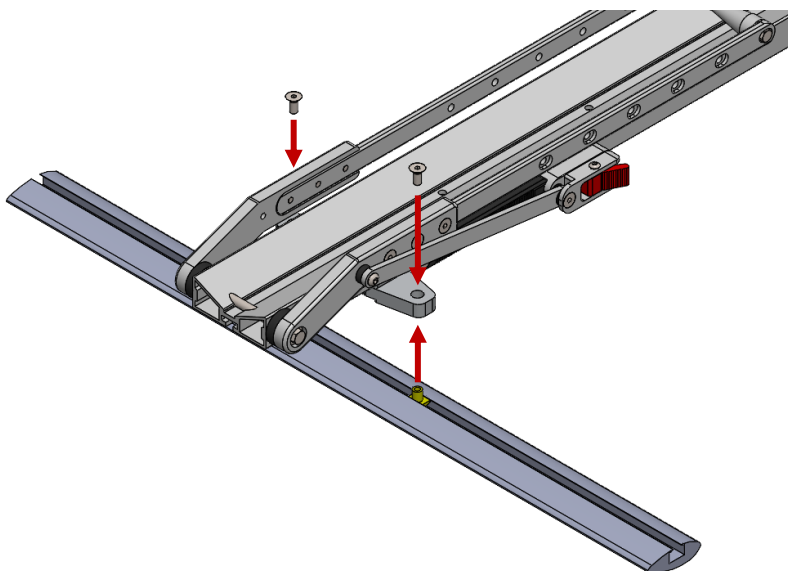

Note: *Washers and Spacers are for minimum adjustments in length if needed.*

Loading Bikes

- To open Bent Arm, depress button and lift up on Bent Arm.

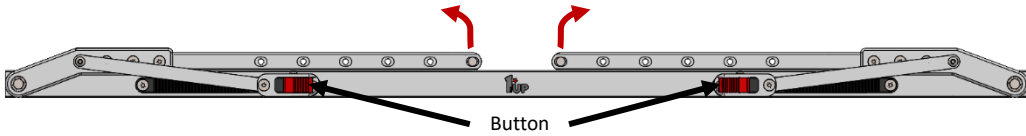

- To disengage Domino, depress Button and lift up on outer Domino as shown below.
- Once Domino is disengaged, Bent Arm will have free motion without depression of button.

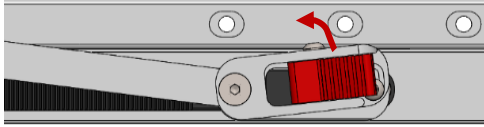

- To engage Domino, press down on outer Domino until Button snaps back into place.

Note: Domino must be engaged to secure bike. Failure to engage Domino can result in damage to bike.

- Open Bent Arms on both driver and passenger side.
- Set bike on Tray in desired position and pivot Bent Arms down to firmly contact tires.
- When loading multiple bikes, stagger them to avoid seat and handlebar interference. E.g., front tire of bike one on driver side, front tire of bike two on passenger side, etc.



Note: Spool must contact tire within specified range. Bike is not secured in rack if spool is located outside of specified range.

- To adjust spool location, remove hex nut and washer with a ½" wrench.
- Slide bolt out of Spools and re-assemble Spools in desired wheel position, firmly tightening hex nut.



Additional Instructions

- Remove road debris off nuts and bolts to prevent corrosion.
- Inspect hardware on Rack periodically to ensure proper working conditions.
- Certain car wash chemicals may damage Rack finish. Please use caution when cleaning vehicle and/or Rack

Questions or comments? Contact our support team via email at email@1up-usa.com