

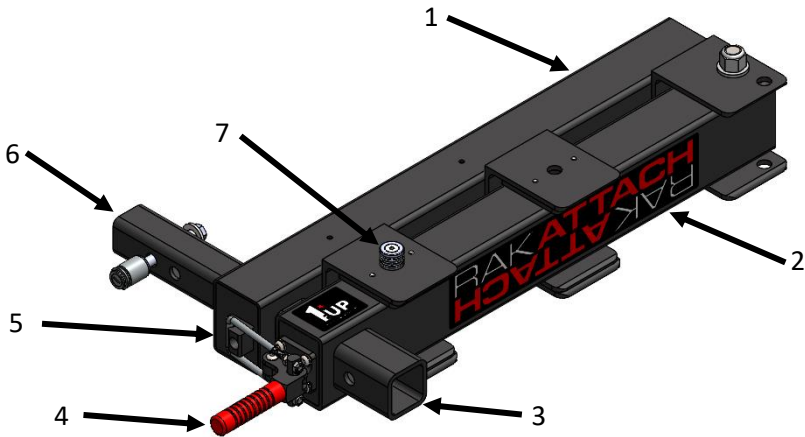

RAKATTACH 2.0

Parts List:

- | | |
|--------------|-----------------|
| 1) Fixed Arm | 5) Hook |
| 2) Swing Arm | 6) Shank |
| 3) Receiver | 7) Magnetic Pin |
| 4) Latch | |



In the Box:

- RakAttach 2.0
- Latch & Hook
- (6) 5/16-18 Button Heads
- (6) 5/16" Lock Washers
- 3/16" Allen Wrench
- Anti-Wobble Bracket, Pin, Washer and Lock

Tools Required:

- 3/16" Allen Wrench (Included)
- 3/4" Wrench
- 1/2" Wrench

Product Notes:

- Available in Medium or Large configurations.
- Fits 2" receivers.

Step 1:

- Insert Magnetic Pin into Fixed Arm hole.

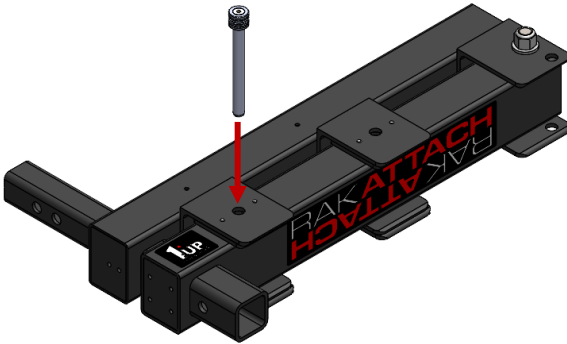

Step 2:

- Insert Anti-Wobble Bracket into RakAttach 2.0 Shank. Pay attention to side of welded nut.
- Slot in bracket goes in last. Slot used for inserting flat head screwdriver to remove or adjust depth.

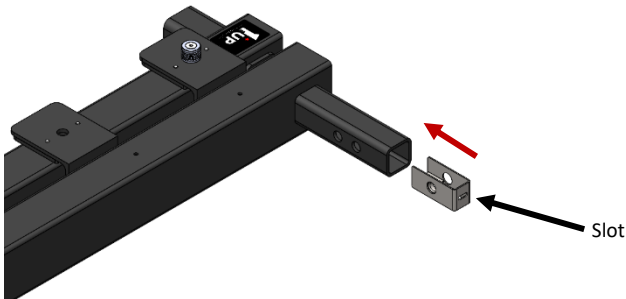

Step 3:

- Insert RakAttach 2.0 Shank into vehicle receiver.
- Align receiver hitch pin hole with Shank hole and Anti-Wobble Bracket. Insert and tighten supplied Hex Anti-Wobble Pin and Washer (same side as welded nut) using 3/4" wrench.

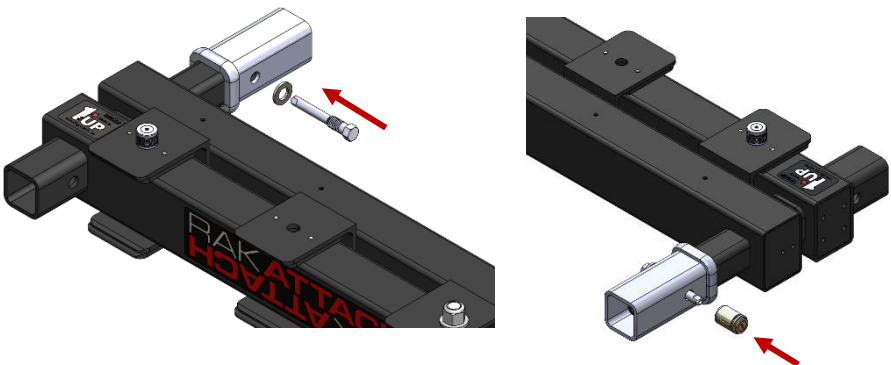

Step 4:

- Install Hook and Latch using supplied 5/16-18 Button Heads, 5/16" Lock Washers and 3/16" Allen Wrench (Latch Handle and U-Bolt will need to be rotated to install fasteners).

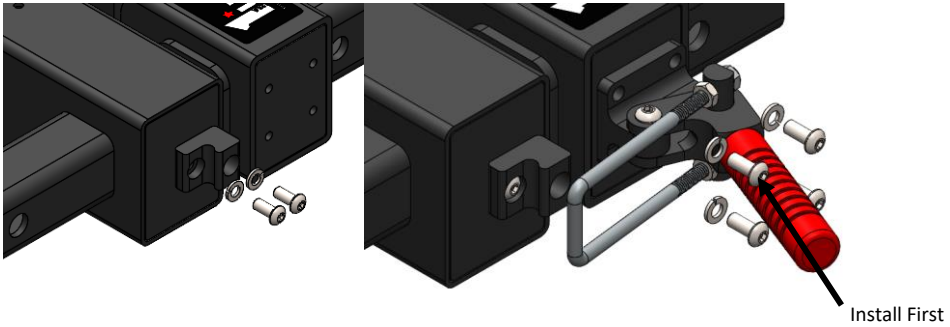

Step 5:

- Verify Latch requires significant force to close. To increase or decrease clamping force, use 1/2" wrench to adjust four nuts found on U-Bolt.

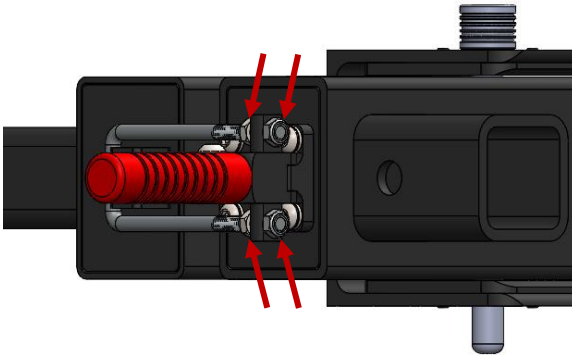

Warning

- Read and follow all instructions when using swing arm adapter.
- Swing arm adapter cannot be used for towing.
- When operating swing arm adapter stay clear of pinch point.

Using RakAttach 2.0

- Verify RakAttach 2.0 is installed properly.
- Install rack or accessory into RakAttach 2.0 Receiver.
- Use Hitch Pin hole in RakAttach 2.0 Receiver if applicable.

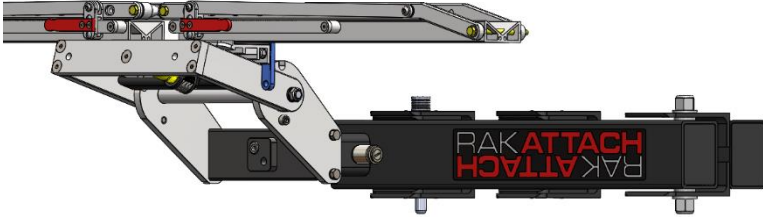

- To swing RakAttach 2.0 to open position, release Latch, pull Magnetic Pin and rotate out.
- Once in open position, install Magnetic Pin in Secondary Hole.

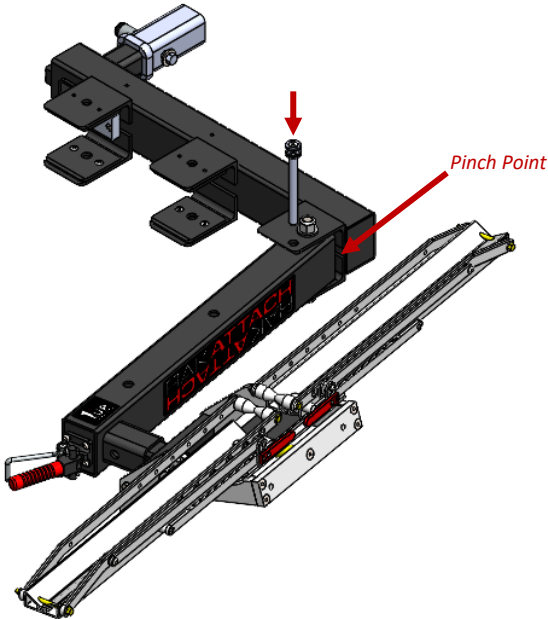

- Reverse steps above to return to closed position. Ensure Magnetic Pin and Latch are installed properly before transporting.

Additional Instructions

- Remove road debris off nuts and bolts to prevent corrosion.
- Inspect hardware on accessory periodically to ensure proper working conditions.
- Certain car wash chemicals may damage finish. Please use caution when cleaning vehicle and/or accessory.

Questions or comments? Contact our support team via email at email@1up-usa.com