

RACK > STASH

RS Equip-D AO Holder

In the Box:

- RS Equip-D AO Holder
- Installation Hardware

Tools Required:

- Drill
- 1/4" Drill Bit
- 1/2" Socket and Ratchet
- Tape Measure
- Level
- 5/16" Allen Wrench

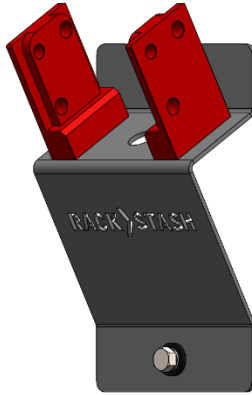

Installation

- Begin by finding a wall location to install. Unit requires one stud for mounting. 27" minimum clearance required beyond both ends of unit.
- Use level and tape to mark and drill 1/4" pilot holes in wall for mounting. Mounting requires two holes.
- Use supplied lags and washers to install unit. 3" lags used for mounting. Lags should be tightened firmly.

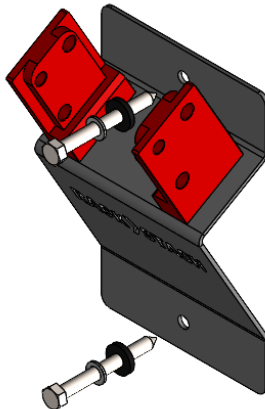

Storing Add-On

Add-On mounts in same manner as installing to base rack (5/16" Allen Wrench required.) **Two Add-Ons maximum.**

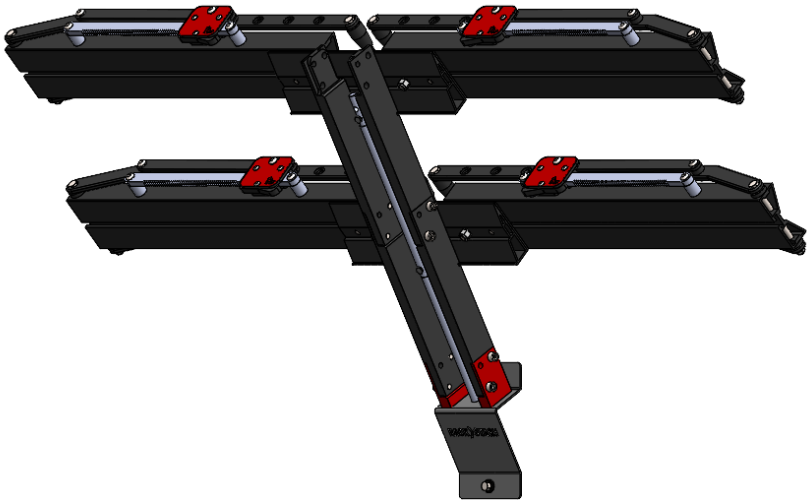
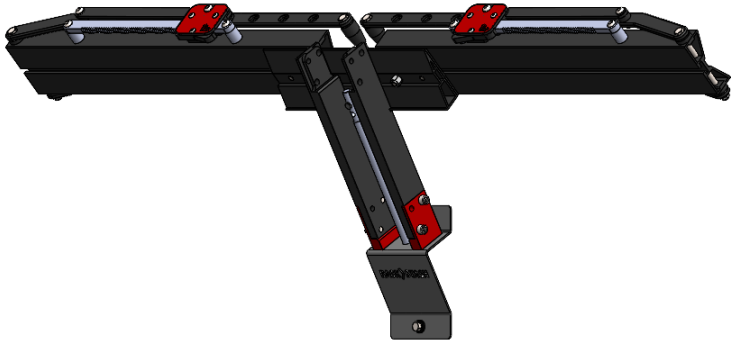

Additional Instructions

- Use **caution** while taking steps to install RS Equip-D AO Holder.
- Inspect RS Equip-D AO Holder periodically to ensure proper working conditions.

Questions or comments? Contact our support team via email at email@1up-usa.com

Warning/Disclaimer

Manufacturer and seller expressly disclaim any and all liability for personal injury, property damage or loss, whether direct, indirect, or incidental, resulting from the incorrect mounting, improper use, inadequate maintenance, or neglect of this system.

Manufactured by: 1UP USA