

Parts List

- 1) Stand
- 2) Outer Leg Assembly
- 3) Inner Leg Assembly

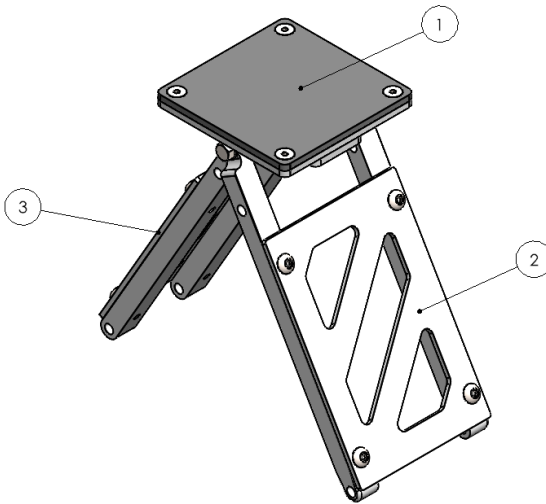

In the Box:

- Peg Stand
- (2) 3/8" Detent Pins

Product Notes:

- Compatible with Moto Rack.
- Only use on Bikes that have heavy duty skid plate with heights ranging from 8"-14" tall.

Installation/Use

Warning: ONLY use with Bikes that have heavy duty skid plate. Does not work on frame of Bike.

- With Bike loaded on Rack and stabilized by Bent Arm Assemblies, unfold Peg Stand and align it between Tray edges.
- Use two of six holes through Tray to pin Legs of Stand at a height where Peg Stand is below skid plate by 1-2".

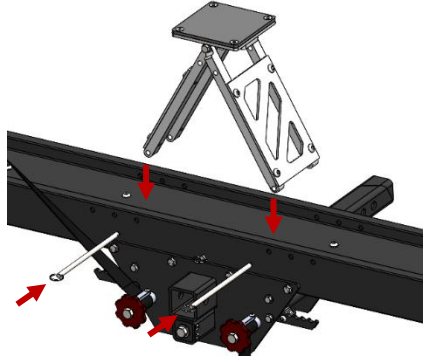

- Focusing on Ratcheting Mechanism located directly under foot pegs. Loosen 1/4"-20 Strap Clamp Button Head Screws with 5/32" Allen Wrench.
- Hold up left foot peg Strap until bottom of S-hook is at top of foot peg.
- Pull remaining Strap slack through Strap Clamp and tighten 1/4"-20 Strap Clamp Button Head Screws.
- Repeat with right foot peg Strap.

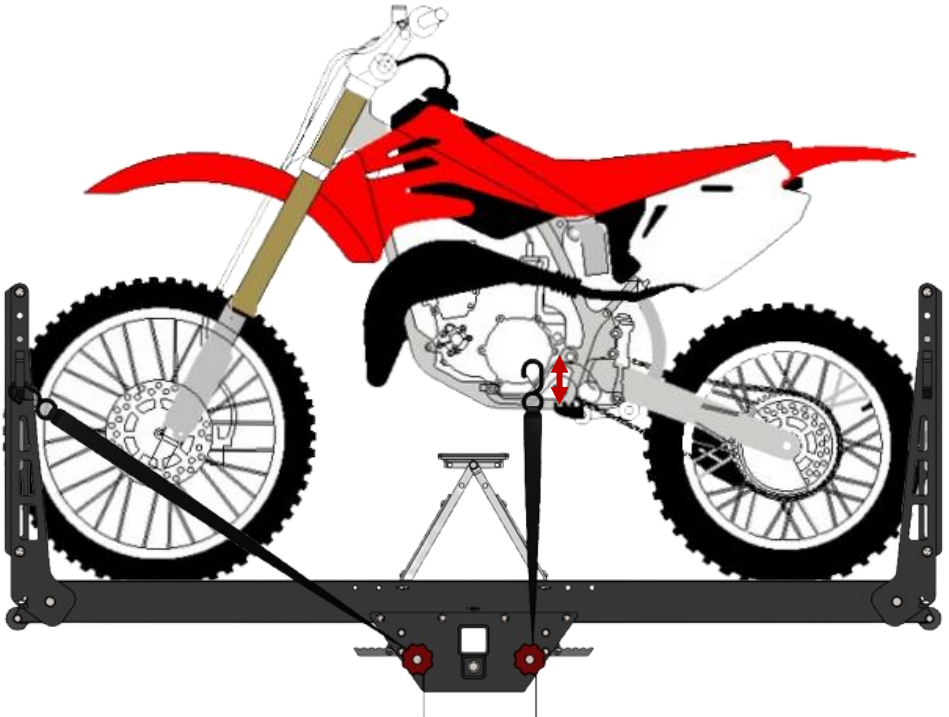

- Clip S-hooks to their respective foot pegs.
- Tension Ratchet Assembly connected to foot peg until skid plate on Bike contacts Peg Stand. Once initial contact is made, Ratcheting Mechanism should tighten at least one more tooth.
- Store any Strap slack by tying up or cutting Strap.
- Tension front Bent Arm Assembly to secure front wheel.
- Close rear Bent Arm Assembly onto rear wheel.
- Replace both Pins for front and rear Bent Arm Assemblies.

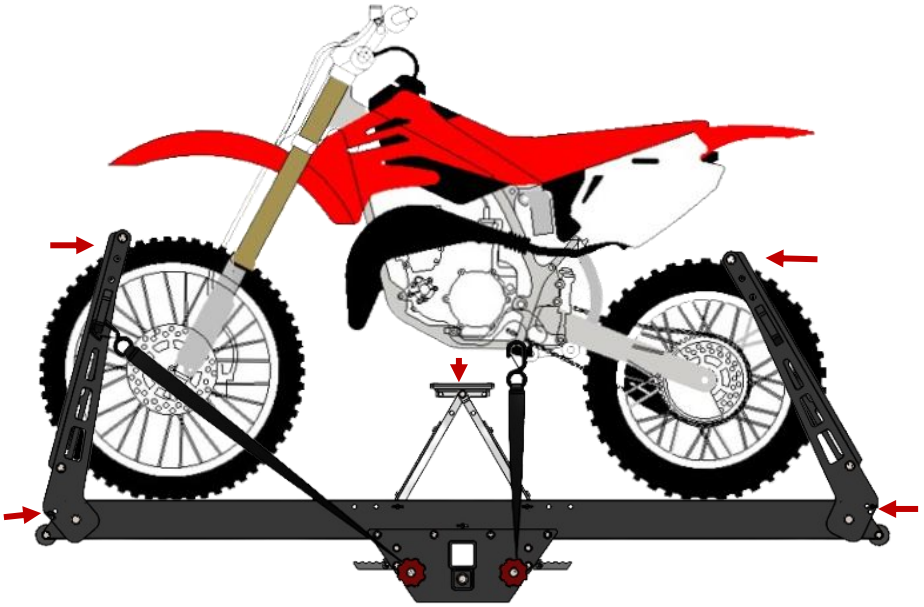

Warning: Failure to follow above instructions may cause severe damage to Bike and/or Rack.

Additional Instructions

- Remove road debris off nuts and bolts to prevent corrosion.
- Inspect hardware on Accessory periodically to ensure proper working conditions.
- Certain car wash chemicals may damage Accessory finish. Please use caution when cleaning vehicle and/or Accessory.

Questions or comments? Contact our support team via email at email@1up-usa.com