



For additional info including video instructions, detailed weight ratings, and more, scan the code.



CARGO CARRIER

Parts List

- | | |
|--------------------------------|---------------------------------|
| 1) Hitch Bar | 8) Black Bar |
| 2) Cargo Side Plate, Driver | 9) Gold Bar |
| 3) Cargo Pivot Beam, Driver | 10) Gold Bar Support |
| 4) 21" Cargo Extrusion | 11) Cargo Pivot Beam, Passenger |
| 5) Cargo Side Plate, Passenger | 12) Tap Plate |
| 6) Threaded Rod Tube | 13) 48" or 60" Cargo Tray |
| 7) Gold Bar Knob | 14) 48" or 60" Cargo Extrusion |

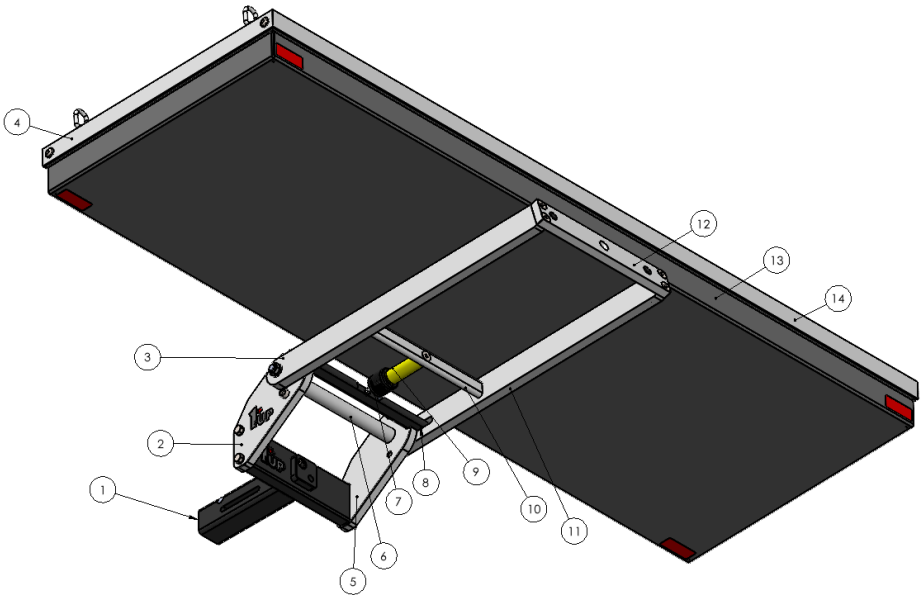

In the Box:

- Cargo Hitch Assembly
- 48" or 60" Cargo Tray Assembly
- Cargo Hardware Package

Product Notes:

- Multi-purpose rugged carrier is rated for up to 380 lb. on Class III + receiver.
- Extrusion rail accepts 5/16" SAE carriage bolts 360 degrees around cargo tray for optimal tie-down locations or mounting of additional accessories.
- Offered in 48" Tray or 60" Tray configurations.
- Compatible with two Add-Ons (sold separately).

Step 1:

- Remove Cargo Hitch Assembly and Cargo Tray from shipping boxes.
- Remove Sticker covering Hitch Bar Ball.

Step 2:

- Position Cargo Hitch Assembly on stable nonabrasive surface with 5/16"-18 tapped holes of Pivot Beams facing upward.
- Align holes of Cargo Tray with 5/16"-18 tapped holes of Pivot Beams.
- Place plastic washer onto end of each 5/16"-18 x 3/4" BHSCS.
- Fasten 5/16"-18 BHSCS into tapped holes using 3/16" Allen wrench. Tighten until snug.

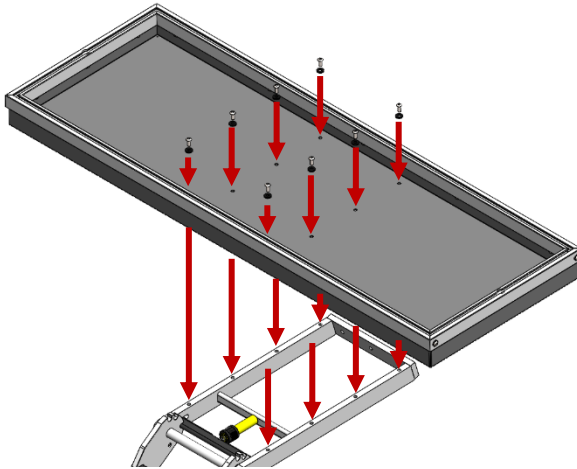

Step 3:

- Insert 5/16"-18 x 3/4" CB through milled hole in 21" Cargo Extrusion.
- Slide 5/16"-18 CB along 21" Cargo Extrusion to desired mounting location.
- Place plastic washer and metal washer on to end of 5/16"-18 CB.
- Thread 5/16" Eye Nut onto 5/16"-18 CB, tighten firmly. Repeat for other instances.

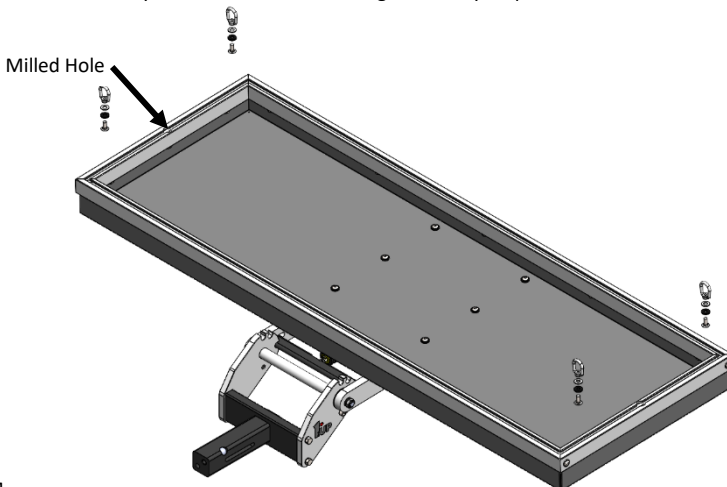

Step 4:

- Insert Cargo Carrier to desired depth in receiver. Ball must be inserted a minimum of 2". Slide Hitch Pin through receiver pin hole and Slotted Hitch Bar. Install Lock Head to end of Locking Pin.

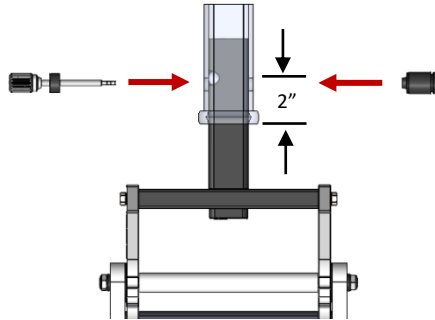

Note: *Silver ball should not stick out front of receiver.*

Step 5:

- Pivot Cargo Carrier into storage position by pulling up on Black Bar and lifting upward on Tap Plate.

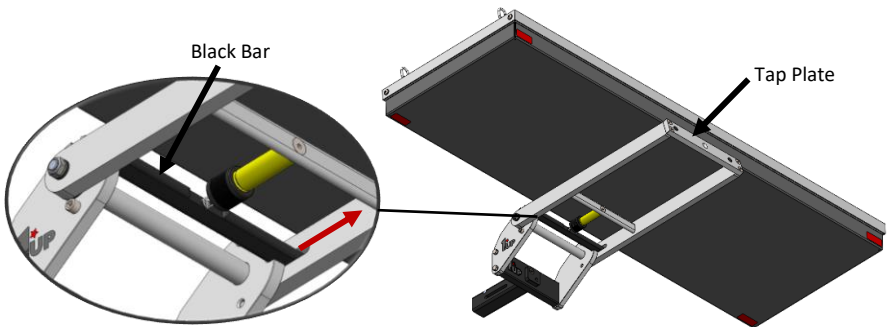

Note: *See Rack Positions on page 4 for more information.*

Step 6:

- Tighten Security Hitch Bolt firmly with gold Security Wrench provided.

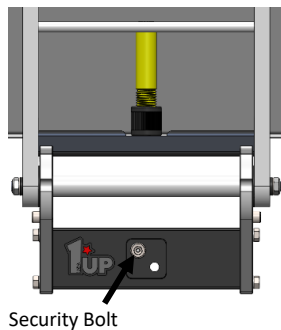

Note: *Do not tighten Security Hitch Bolt if Hitch Bar is not inserted into a receiver.*

Pivoting the Rack

- Pull Black Bar out away from Hitch while lifting on Tap Plate.
- Pivot Rack toward desired position and release Black Bar. **Ensure Black Bar fully engages in slots.**
- **Once Black Bar is engaged, tighten Gold Bar Knob against Black Bar to lock in place.**

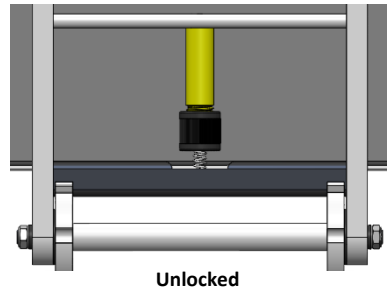
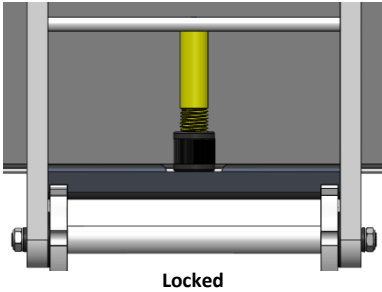

Warning: *Failure to follow above instructions may cause severe damage to cargo and/or Cargo Carrier.*

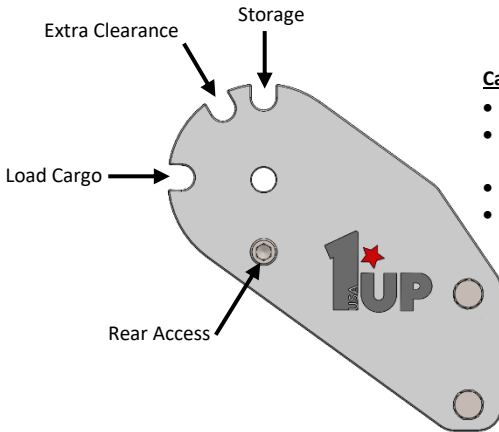

Cargo Carrier Positions

- Storage - traveling with no cargo.
- Extra Clearance position - traveling with no cargo, but a large bumper or tire blocks storage position.
- Load Cargo - transport cargo.
- Rear Access - tailgate or trunk accessible with cargo.

Note: *In rear access position, Black Bar will not lock into place. Not for transporting.*

Additional Instructions

- Tighten Security Hitch Bolt periodically.
- Remove carrier from receiver at least every two weeks and clean receiver so carrier does not seize in receiver.
- Remove road debris off nuts and bolts to prevent corrosion.
- Inspect hardware on Cargo Carrier periodically to ensure proper working conditions.
- Certain car wash chemicals may damage Cargo Carrier finish. Please use caution when cleaning vehicle and/or Cargo Carrier.
- Failure to follow above instructions, or misuse of Cargo Carrier, may void warranty.

Questions or comments? Contact our support team via email at email@1up-usa.com