

### In the Box:

- 1UP USA Add-On Frame
- Hardware Packet
- 15 Degree Plate
- Driver Tray
- Passenger Tray
- 3/16" Allen Wrench

### Step 1:

- Pivot Base Rack into the Storage position (parallel to the rear of vehicle).
- Remove both plastic caps found in Tap Plate of Base Rack and partially thread in two supplied Security Bolts.

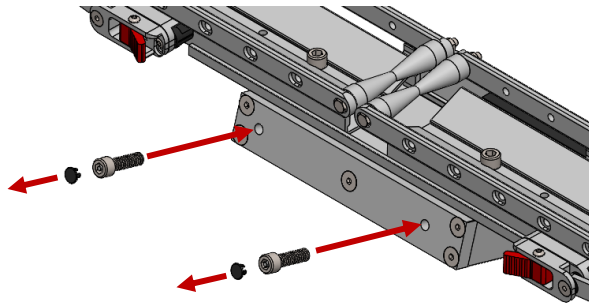

### Step 2:

- Place Add-On onto base rack by aligning Key Hole Plate slots with installed Security Bolts.
- Slide Add-On to the right engaging Security Bolts into narrow portion of Key Hole Plate slots.
- With Base Rack Security Wrench, tighten Security Bolts.

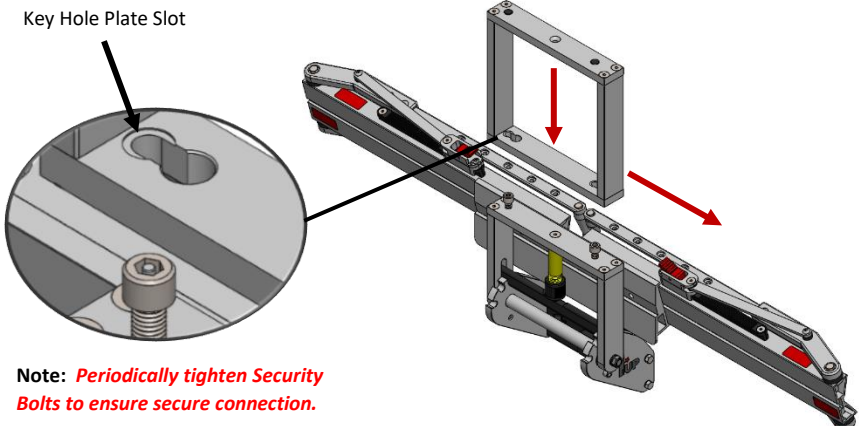

**Note:** *Periodically tighten Security Bolts to ensure secure connection.*

### Step 3:

- Place 15 Degree Plate onto Pivot Beams with taller side closest to Hitch and flat side facing up.
- Firmly fasten 15 Degree Plate onto Pivot Beams using supplied 5/16"-18 X .75" Flat Head Screws and 3/16" Allen Wrench.

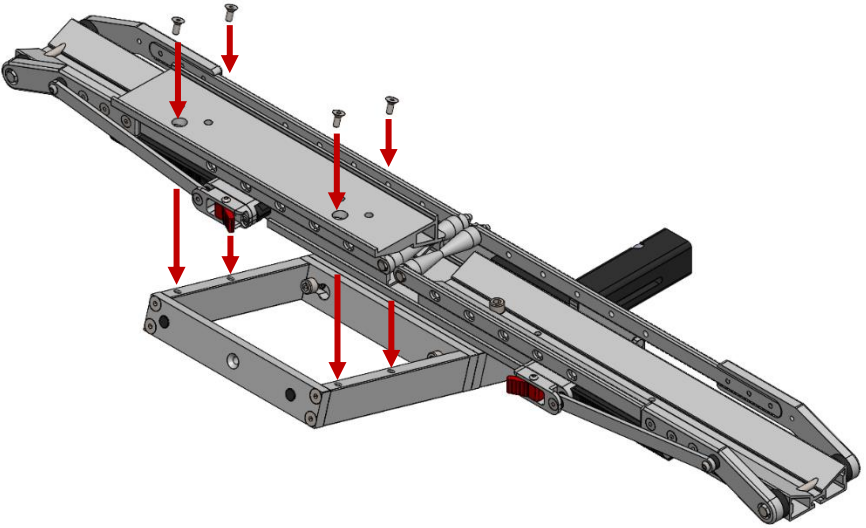

### Step 4:

- Place Driver Tray on driver side of rack, ensuring Button is facing away from Hitch as shown below.
- Firmly fasten Tray to 15 Degree Plate using supplied 1/2"-13 X 1.25" Socket Head and Security Wrench.
- Repeat for Passenger Side.

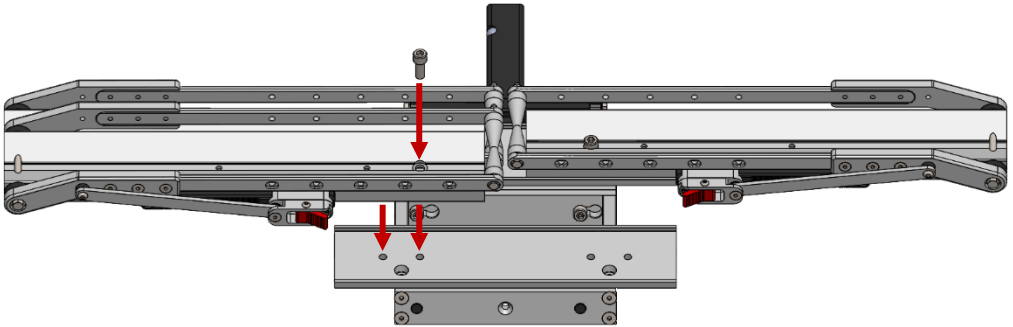

- Notes:**
- *Inner holes accommodate wheelbases up to 54".*
  - *Outer holes accommodate wheelbases 54" to 58".*
  - *Trays can be offset from Driver to Passenger side based on user preference.*

## **Installing Add-On Lock (if applicable)**

Not included with Add-On purchase (sold separately)

- If Add-On is already installed to base rack, remove right Security Bolt. If installing a new Add-On, Add-On Lock Bolt will be applied to right threaded hole of Base Rack Tap Plate.
- Slide locking washer and flat washer over Add-On Lock Bolt and thread into Tap Plate hole.
- With Base Rack Security Wrench, tighten Add-On Lock Bolt.
- Apply Lock Head to end of Add-On Lock Bolt. Key must be inserted and turned to install Lock Head.

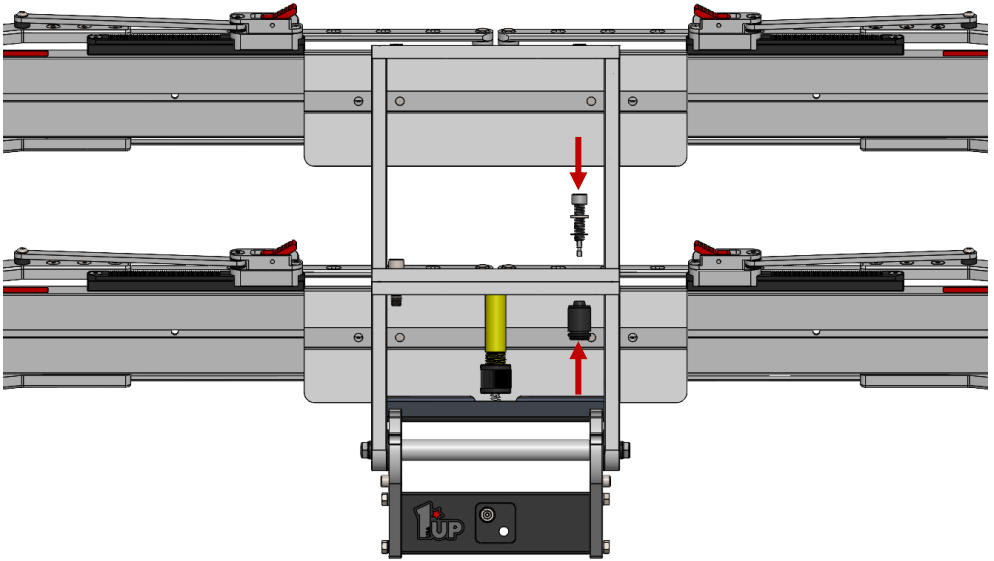

## **Additional Instructions**

- Remove road debris off nuts and bolts to prevent corrosion.
- Inspect hardware on Rack periodically to ensure proper working conditions.
- Certain car wash chemicals may damage Rack finish. Please use caution when cleaning vehicle and/ or Rack.

Questions or comments? Contact our support team via email at [email@1up-usa.com](mailto:email@1up-usa.com)