

In the Box:

- 1UP USA Equip-D Add-On
- (4) Pivot Beam Bolts
- (1) Add-On Rod
- (1) Detent Pin

Step 1:

- Rotate Base Rack into Storage position (parallel to the rear of vehicle).
- Remove both Red Detent Pin and Detent Pin and slide out Handle.
- Unthread Pivot Beam Bolts holding End Cap.
- Remove End Cap.

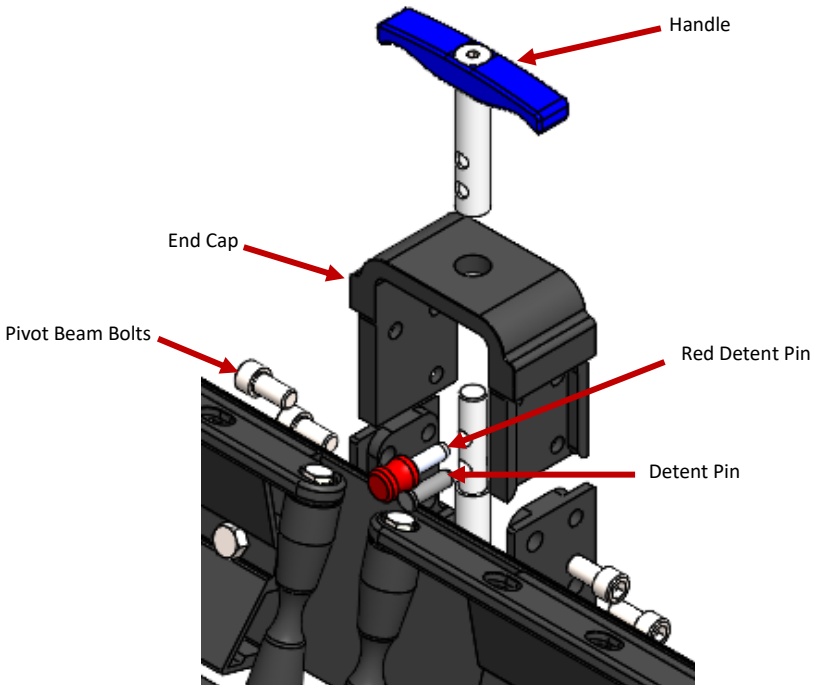

Step 2:

- Position Rack with Hitch Bar facing upwards and place on a stable nonabrasive surface.
- Rotate Trays outward 90° into loading position.

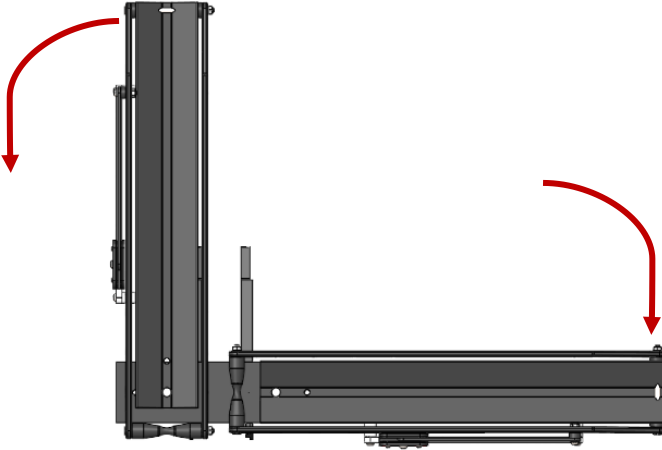

Step 3:

- Insert 3/8-16 SHCS bolt into holes shown below and tighten firmly with Multi Tool.

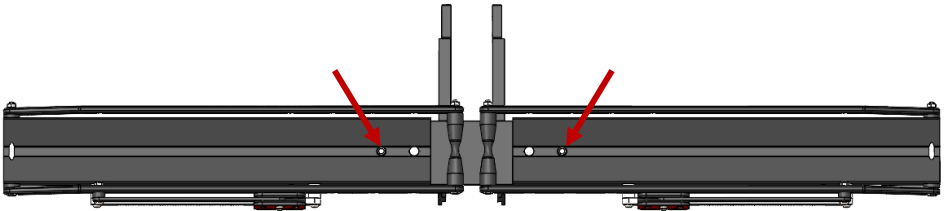

Step 4:

- Slide Add-On and Add-On Rod onto Base Rack as shown below.
- Reinstall Pivot Beam Bolts from previous step to secure Add-On.
- Tighten firmly.

Note: *Periodically tighten Pivot Beam Bolts to ensure secure connection.*

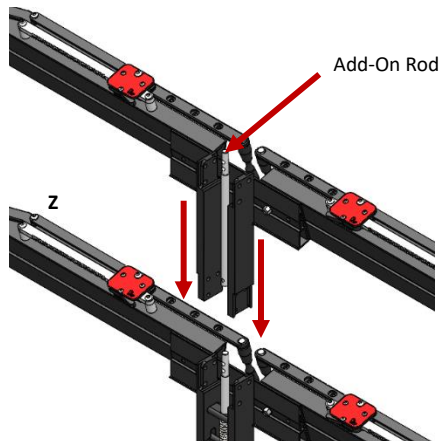

Step 5:

- Place End Cap onto Add-On. Secure End Cap with supplied Pivot Beam Bolts.
- Line up holes on Pull Rods and install Detent Pins to join Pull Rods and Handle.

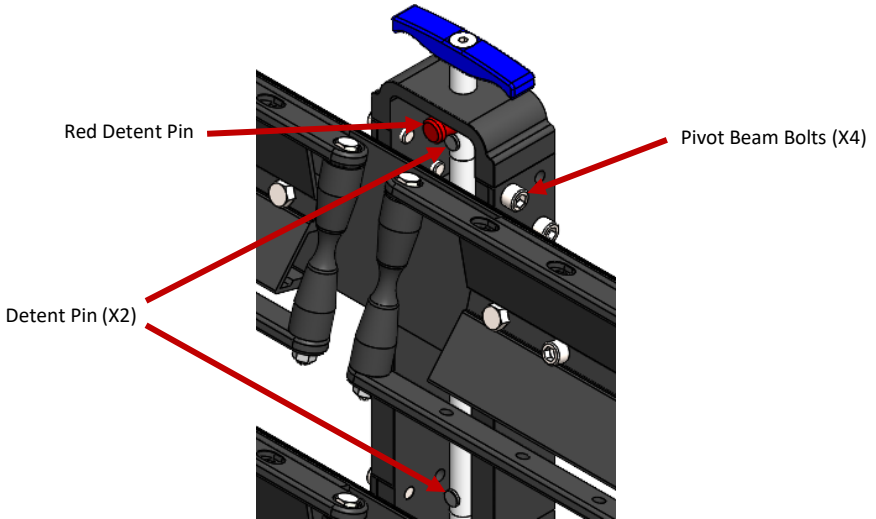

Installing Add-On Lock (if applicable)

Not included with Add-On purchase (sold separately)

- Install Add-On Lock Pin through holes and apply Lock Head to end of Add-On Lock Pin.
- Key must be inserted and turned to install lock head.

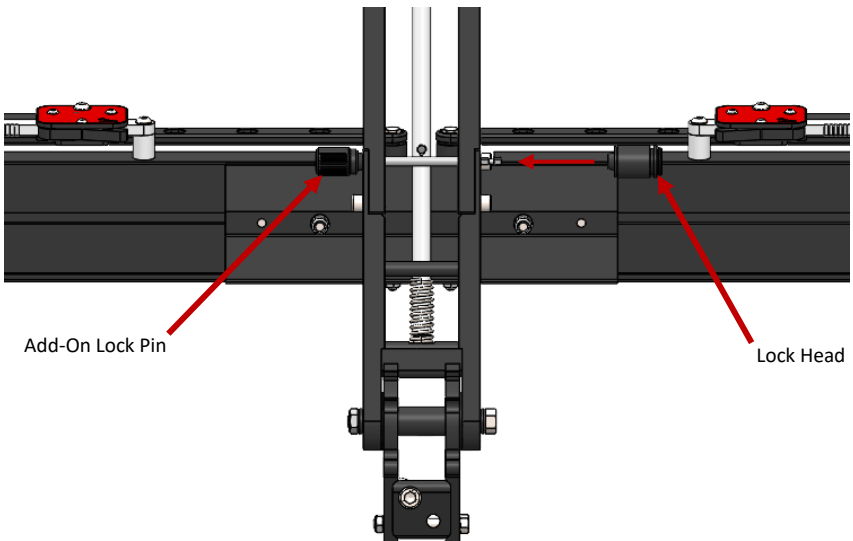

Additional Instructions

- Remove road debris off nuts and bolts to prevent corrosion.
- Inspect hardware on Rack periodically to ensure proper working conditions.
- Certain car wash chemicals may damage Rack finish. Please use caution when cleaning vehicle and/ or Rack.

Questions or comments? Contact our support team via email at email@1up-usa.com