



6" Rise/Drop Hitch Receiver

In the Box:

- 6" Rise/Drop Hitch Receiver
- Velcro Strap
- Hex Anti-Wobble Locking Pin
- M16 Zinc Washer
- Anti-Wobble Lock

Tools Required:

- 3/4" Wrench

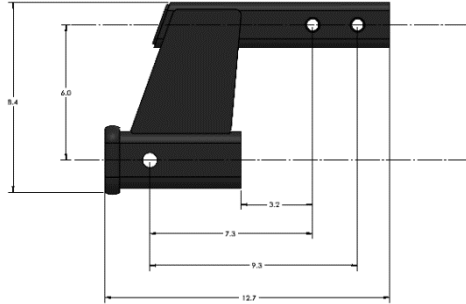

Warning!

- Hitch Extender capacity is the **LOWEST** of the following:
 - 66% of tongue weight rating of vehicle
 - 300 lbs
- **DO NOT USE WITH HITCH ADAPTERS OR EXTENDERS**
- **DO NOT CUT WELD OR MODIFY THIS HITCH EXTENDER.**
- Exceeding the limits specified may result in death, personal injury and/or property damage.
- The manufacturer will not be responsible for any personal injury and/or damage caused by the misuse of this product.

Installation

- Insert unit into receiver of vehicle.
- Pay attention to side of threaded insert of 6" Rise/Drop Hitch Receiver.
- Insert Hex Anti-Wobble Locking Pin through hole of vehicle receiver. (Same side as threaded insert)
- Use 3/4" Wrench to tighten Hex Anti-Wobble Locking Pin.
- Attach Anti-Wobble Lock to end of Hex Anti-Wobble Pin.
- Attach Velcro Strap if applicable.

Additional Instructions

- Use **caution** while taking steps to install 6" Rise/Drop Hitch Receiver.
- Inspect 6" Rise/Drop Hitch Receiver periodically to ensure proper working conditions.

Questions or comments? Contact our support team via email at email@1up-usa.com

INS67